



BHADRAK ENGINEERING SCHOOL & TECHNOLOGY  
(BEST), ASURALI, BHADRAK

# Fluid Mechanics

## (Th- 03)

(As per the 2020-21 syllabus of the SCTE&VT,  
Bhubaneswar, Odisha)



Fourth Semester

Mechanical Engg.

**Prepared By:** *Er P K Nath*

## FLUID MECHANICS (TH-03)

SL.N O	CHAPTER	TOPICS	PERIOD AS PER SYLLABUS	PERIODS ACTUALLY NEEDED	EXPECTED MARKS
01	01	PROPERTIES OF FLUID	08	06	15
02	02	FLUID PRESSURE AND ITS MEASUREMENT	08	09	15
03	03	HYDROSTATICS	08	06	12
04	04	KINEMATICS OF FLOW	08	08	18
05	05	ORIFICE, NOTCHES & WEIR	08	07	10
06	06	FLOW THROUGH PIPE	10	06	15
07	07	IMPACT OF JET	10	10	15
		TOTAL	60	52	100

P.K.NATH SIR

# CHAPTER-01

## PROPERTIES OF FLUID

### 1.1 INTRODUCTION

Fluid mechanics is the branch of engineering science which deals with the study of fluids and its properties and forces which cause motion of different layer.

#### FLUID:

Fluid is a substance as a liquid or gas i.e. capable of flowing and yields easily through small external pressure.

Ex- water, air, petrol, etc

### 1.2 PROPERTIES OF FLUID:

#### 1) Density/ Mass Density

- Density or mass density of a fluid is defined as the ratio of mass of a fluid to its volume. Thus mass per unit volume of a fluid is called density.
- It is denoted by  $\rho$ .

#### Mathematically:

- Mass density ( $\rho$ )= mass of fluid/volume of fluid
- Units – gm/cm<sup>3</sup>, kg/m<sup>3</sup>, gm/cc
- The value of density of 1000 kg/m<sup>3</sup> or 1 gm/cm<sup>3</sup>
- Density of water is maximum at 4°C

#### 2) Specific Weight or Weight density:

- Specific weight or weight density of a fluid of a fluid is defined as the ratio between weight of the fluid to its volume.
- It is denoted by  $w$ .
- Mathematically,

- Specific Weight = weight of the fluid / volume of the fluid  
= (mass of fluid × acceleration due to gravity) / volume of the fluid

$$w = \rho \times g$$

- Units-  $\text{N/m}^3$ ,  $\text{kgf/m}^3$ ,  $\text{dyne/cm}^3$
- Weight density of water is  $9810 \text{ N/m}^3$

### **3) Specific gravity:**

- It is defined as the ratio between density or weight density of a fluid to the density or weight density of a standard fluid.
- It is also known as relative density.
- It is denoted by S.
- Mathematically,  
specific gravity = (density or weight density of a fluid) / (density or weight density of standard fluid)
- For gas standard fluid is air, for liquid standard fluid is water.

### **4) SPECIFIC VOLUME:**

- Specific volume of a fluid is defined as the volume occupied by a unit mass or volume per unit mass of a fluid is called specific volume.
- Specific volume = volume of fluid / mass of fluid  
=  $1 / (\text{mass of fluid} / \text{volume})$   
=  $1 / \rho$
- It is reciprocal of density. It is expressed in  $\text{m}^3/\text{kg}$

### PROBLEM-01

Calculate the specific gravity, density and weight density of one litre of a liquid which weighs 7N.

#### Data given

Volume= 1 litre =0.001 m<sup>3</sup>

Weight= 7 N

#### To be found

Specific gravity(S) =?

Density ( $\rho$ )=?

Weight density(w) =?

#### Calculation

- 1) Specific weight (w) = weight/volume  
=  $7/0.001=7000 \text{ N/m}^3$
- 2) Density ( $\rho$ )= weight density/acceleration due gravity  
=  $7000/9.81= 713.5 \text{ kg/m}^3$
- 3) Specific gravity(S)= density of liquid/ density of water  
=  $713.5/1000=0.713$  (ans)

### PROBLEM-02

Calculate the density, specific weight and weight of one litre of petrol of specific gravity=0.7.

#### Data given

Specific gravity(s)= 0.7

Volume= 1 litre= 0.001 m<sup>3</sup>

#### To be found

Density ( $\rho$ )=?

Specific Weight ( $w$ )=?

Weight ( $w$ )=?

### Calculation

We know specific gravity= density of liquid/ density of standard fluid

Hence density of liquid= sp. Gravity  $\times$  density of standard fluid

$$= 0.7 \times 1000 = 700 \text{ kg/m}^3$$

Specific weight( $w$ )= density  $\times$  acceleration due to gravity

$$= 700 \times 9.81 = 6867 \text{ N/m}^3$$

We know weight density= weight/volume

$\therefore$  weight= weight density  $\times$  volume

$$= 6867 \times 0.001 = 6.867 \text{ N}$$

### **1.3 VISCOSITY:**

- Viscosity is defined as the property of a fluid which offers resistance to the movement of one layer over another adjacent layer.
- When two layer of a fluid a distance  $dy$  apart move one another at different velocities, say  $u$  and  $u+du$  as shown in fig. below, the viscosity together with relative velocity causes a shear stress acting between the fluid layers.
- The top layer causes a shear stress on the adjacent bottom layer and the bottom layer causes a shear stress on adjacent top layer, this shear stress is directly proportional to the rate of change of velocity with respect to  $y$ .
- Mathematically,  $\tau \propto (du/dy)$   
$$\tau = \mu (du/dy)$$

where,  $\mu$  = constant of proportionality is known as coefficient of viscosity or dynamic viscosity.

$(du/dy)$  = is called velocity gradient or rate of change of velocity

$$\mu = \tau / (du/dy)$$

units-  $N\ S/M^2$ ,  $Dyne\ S/ Cm^2$ ,  $KgF\ S/ M^2$

One  $Dyne\ S/ Cm^2$  is called one poise.

### **1.3 KINEMATIC VISCOSITY:**

It is the ratio between dynamic viscosity to the density of the fluid. It is denoted by  $\nu$ .

Mathematically,

Kinematic viscosity = Dynamic viscosity / Fluid mass density

$$\nu = \mu / \rho$$

units:- $m^2/s$ ,  $cm^2/s$

$1\ cm^2/s = 1\ stoke$

### **1.3 SURFACE TENSION**

- It is defined as a tensile force acting on the surface of a liquid in contact with a gas or on the surface between two immiscible liquids such that the contact surface behaves like a stretched membrane.
- It is the property of a fluid by virtue of which its free surface behaves like a stretched membrane and supports comparatively heavier object placed over it.
- Units:  $N/m$
- Surface tension of liquid droplet,  $P=4\sigma/d$



- Surface tension of a hollow bubble,  $P=8\sigma/d$
- Surface tension of a liquid jet,  $P=2\sigma/d$

### 1.3 CAPILLARITY:

- it is defined as a phenomenon of rise or fall of a liquid surface in a small tube relative to the adjacent general level of liquid when the tube is held vertically.
- The rise in liquid level is called capillary rise, and the fall of liquid level is called capillary fall.
- Capillary rise,  $\Delta h= \frac{4\sigma\cos\theta}{d \rho g}$   
 $\Theta=0^\circ$  in case of water
- Capillary fall,  $\Delta h= \frac{4\sigma\cos\theta}{d \rho g}$   
 $\Theta=128^\circ$  in case of mercury
- Capillary rise occur in case of water and capillary fall occur in case of mercury.

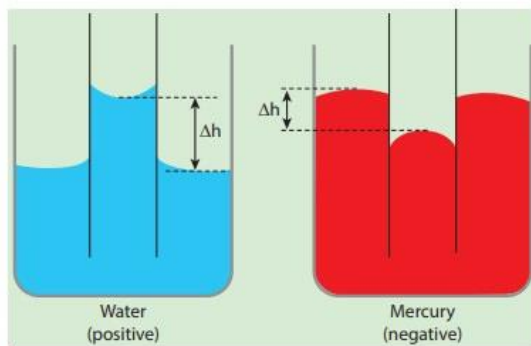

Figure 7.29 Capillary rise or fall

### TYPES OF FLUID

#### (i) Ideal fluid:

The fluid which is incompressible and no viscosity is called ideal fluid. It is an imaginary fluid as all existing fluids have some viscosity.

#### (ii) Real fluid:

A fluid that possesses viscosity is called real fluid. In actual practice all the fluids are real fluid.

**(iii) Newtonian fluid:**

The fluid which obey newtons law of viscosity is called Newtonian fluid.

**(iv) Non-Newtonian fluid:**

The fluid which does not obey the newtons law of viscosity is called Non-Newtonian fluid.

**(v) Ideal plastic fluid:**

A fluid in which shear stress is more than yield value and the shear stress is directly proportional to the rate of shear strain is called ideal plastic fluid.

**SHORT QUESTIONS**

**1) Define mass density and specific gravity? (2019-S)**

- Ans- **Density or mass density** of a fluid is defined as the ratio of mass of a fluid to its volume. Thus mass per unit volume of a fluid is called density.
- It is denoted by  $\rho$ .

### Mathematically:

- Mass density ( $\rho$ ) = mass of fluid/volume of fluid
- Units –  $\text{gm/cm}^3$ ,  $\text{kg/m}^3$ ,  $\text{gm/cc}$

#### **Specific gravity**

- It is defined as the ratio between density or weight density of a fluid to the density or weight density of a standard fluid.
- It is also known as relative density.
- It is denoted by S.
- Mathematically,

$$\text{specific gravity} = \frac{(\text{density or weight density of a fluid})}{(\text{density or weight density of standard fluid})}$$

### 2) Define specific weight and specific volume? (2019-S)

**Ans-Specific weight or weight density** of a fluid of a fluid is defined as the ratio between weight of the fluid to its volume.

It is denoted by w.

Mathematically,

Specific Weight = weight of the fluid / volume of the fluid

$$= \frac{(\text{mass of fluid} \times \text{acceleration due to gravity})}{\text{volume of the fluid}}$$

$$w = \rho \times g$$

- Units-  $\text{N/m}^3$ ,  $\text{kgf/m}^3$ ,  $\text{dyne/cm}^3$

**Specific volume** of a fluid is defined as the volume occupied by a unit mass or volume per unit mass of a fluid is called specific volume.

- Specific volume = volume of fluid/mass of fluid  
=  $1 / (\text{mass of fluid/volume})$   
=  $1 / \rho$
- It is reciprocal of density. It is expressed in  $\text{m}^3/\text{kg}$

### 3) Define specific gravity and state its units? (2019-S)

- It is defined as the ratio between density or weight density of a fluid to the density or weight density of a standard fluid.
  - It is also known as relative density.
  - It is denoted by S.
  - It has no unit.
- 
- Mathematically,  
specific gravity = (density or weight density of a fluid)/  
(density or weight density of standard fluid)

**4) What is kinematic viscosity and states its units? (2019-S)**

Ans-it is defined as the ratio between density or weight density of a fluid to the density or weight density of a standard fluid.

- It is also known as relative density.
- It is denoted by S.
- Mathematically,  
specific gravity = (density or weight density of a fluid)/  
(density or weight density of standard fluid)

**LONG QUESTIONS**

- 1) A volume of 5m<sup>3</sup> of certain fluid weight 20KN. Determine specific gravity, mass density and specific weight of the liquid? (2018-S)**

P.K.NATH SIR

## CHAPTER-02

### FLUID PRESSURE AND ITS MEASUREMENT

#### 2.1 INTRODUCTION

- When a fluid contained in a vessel it exerts force on each side and bottom of the vessel. This force per unit area of a fluid is called fluid pressure or simply pressure.
- Thus force per unit area of a fluid is called fluid pressure.
- Instrument used for measurement of pressure is barometer.
- Units- $N/M^2$ ,  $N/CM^2$ , Dyne/  $CM^2$ , pascal, KPa, etc
- Its bigger unit is bar

$$1 \text{ bar} = 10^5 N/M^2 \text{ or } 10^5 \text{ Pascal}$$

Pressure at a point of height  $h$  from free surface of liquid –

$$P = \rho gh$$

$$h = P/\rho g, \text{ where } P/\rho g \text{ is called pressure head}$$

#### 2.2 PASCAL'S LAW:

It states that the pressure or intensity of pressure at a point in a static fluid is equal in all direction.

$$P_x = P_y = P_z$$

Where  $P_x$ = pressure fluid in X direction

$P_y$  = pressure fluid in Y direction

$P_z$  = pressure fluid in Z direction

#### 2.3 Atmospheric pressure, Absolute, Gauge and Vacuum Pressure

- Usually, pressure on a fluid is expressed in two different ways by assuming two different datums in two different systems.

- In one system, the absolute zero or complete vacuum is adopted as the datum where as in other system, the pressure above the atmospheric pressure is considered.

### **Atmospheric pressure ( $P_{atm}$ )**

The pressure exerted by the envelope of air surrounding the earth's surface is known as atmospheric pressure.

$$P_{atm} = w_{hg} h$$

Where  $w_{hg}$  = weight density or specific weight of fluid

$h$  = height of the fluid in barometric tube.

### **Absolute Pressure ( $P_{ab}$ )**

The pressure which is measured with reference to absolute vacuum pressure or zero pressure is called absolute pressure.

### **Gauge Pressure ( $P_{ga}$ )**

- The pressure which is measured by taking the atmospheric pressure as datum is called gauge pressure.
- This is the pressure which is measured by a pressure measuring instrument.
- The atmospheric pressure is taken as zero.

### **Vacuum Pressure ( $P_{vac}$ )**

- The pressure which is below the atmospheric pressure is called vacuum pressure.
- It is also called suction pressure or negative gauge pressure.

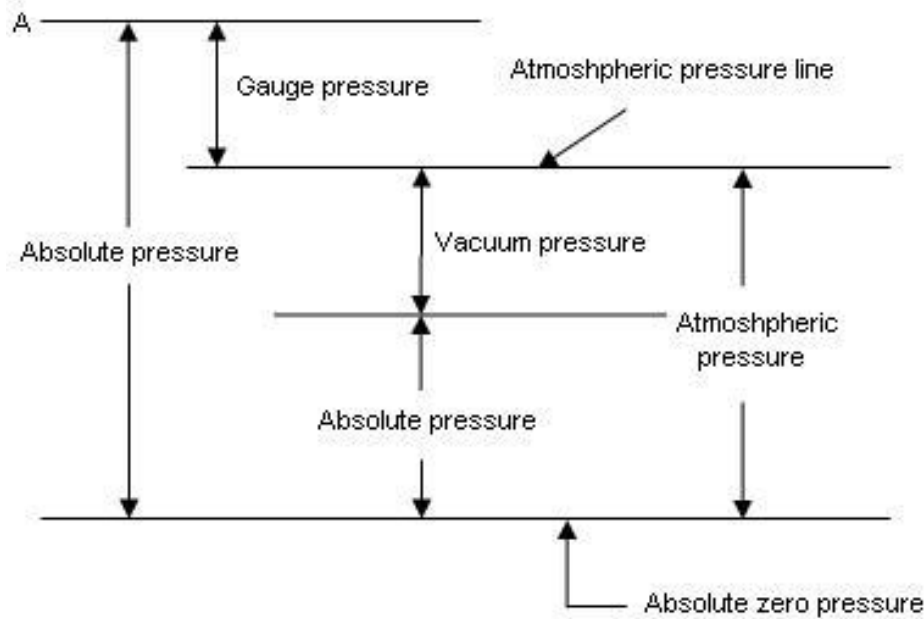

Absolute pressure = Atmospheric Pressure + Gauge Pressure

$$P_{\text{abs}} = P_{\text{atm}} + P_{\text{gauge}}$$

$$P_{\text{abs}} = P_{\text{atm}} - P_{\text{vacuum}}$$

### Problem-1

The reading of a barometer is found to be 760 mm of Hg. What should be the atmospheric pressure in  $\text{N}/\text{M}^2$  and in terms of water if sp. Gravity of Hg is 13.6?

#### Data given

$h_1 = 760$  mm of Hg

$s_1 = 13.6$

we know density ( $\rho_1$ ) =  $13600 \text{ kg}/\text{m}^3$

we know atmospheric pressure

$$P_{\text{atm}} = \rho_1 g h_1 = 13600 \times 9.81 \times 0.760 = 101435.4 \text{ N}/\text{m}^2$$

Let  $h_2$  be the atmospheric pressure in terms of head of water

We know the relationship  $s_1 h_1 = s_2 h_2$

$$13.6 \times 760 = 1 \times h_2$$

$$h_2 = 10.34 \text{ m of water}$$



## PROBLEM-02

A hydraulic press has a ram of 30cm diameter and a plunger of 4.5 cm diameter. Find the weight lifted by the hydraulic press when the force applied at the plunger is 500N.

### Solution

Dia. of ram  $D = 30 \text{ cm} = 0.3 \text{ m}$

Dia. of plunger  $d = 4.5 \text{ cm} = 0.045 \text{ m}$

Force on plunger,  $F = 500 \text{ N}$

Area of ram  $(A) = \pi/4 D^2 = \pi/4 \times 0.3^2 = 0.07068 \text{ m}^2$

Area of plunger  $(a) = \pi/4 d^2 = \pi/4 \times 0.045^2 = 0.00159 \text{ m}^2$

Pressure intensity due to plunger = force on the plunger/area of Plunger =  $F/a = 500/0.00159 = 314465.4 \text{ N/m}^2$

Due to pascal's law the intensity of pressure will be equally transmitted in all direction.

Hence the pressure intensity at the ram =  $314465.4 \text{ N/m}^2$

But pressure intensity at ram = weight/area of ram

$$= W/A = W/0.07068 \text{ N/m}^2$$

Weight =  $314465.4 \times 0.07068 = 22222 \text{ N} = 22.222 \text{ KN. ans}$

## 2.4 PRESSURE MEASURING INSTRUMENT:

The pressure of fluid is measured by the following devices-

- (1) Manometer
- (2) Mechanical gauge

### (1) MANOMETER

Manometers are defined as the devices used for measuring the pressure in a fluid by balancing the column of fluid by the same or another column of the fluid. They are classified as:-

- (a) Simple manometer
- (b) Differential manometer

## **(2) Mechanical gauge**

Mechanical gauge are defined as the devices as the devices used for measuring the pressure by balancing the fluid column by the spring weight or dead weight. The most commonly used mechanical gauges are-

- (1) Diaphragm pressure gauge
- (2) Bourdon tube pressure gauge
- (3) Dead weight pressure gauge
- (4) Bellows pressure gauge

## **SIMPLE MANOMETER**

- A simple manometer consists of a glass tube having one end is connected to the point where pressure is to be measured and other end is opened to the atmosphere.
- Common type of simple manometers are
  - (1) Piezometer
  - (2) U-tube manometer
  - (3) Single column manometer

## PIEZOMETER

It is the simplest form of manometer used for measuring gauge pressure. one end of this manometer is connected where pressure is to be measured and other end is opened to the atmosphere.

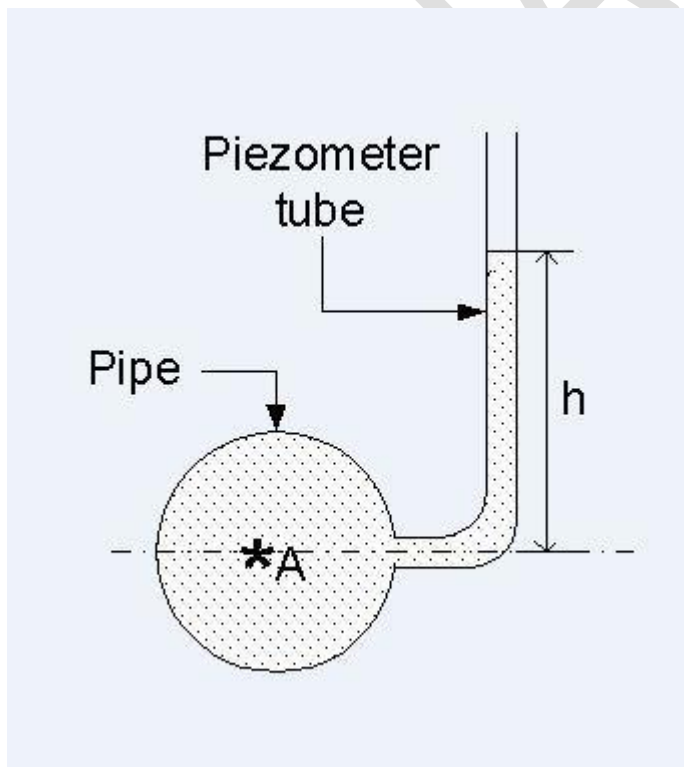

Pressure at A ( $P_A$ ) =  $\rho g h$  N/m<sup>2</sup>

## U-TUBE MANOMETER

- It consists of a glass tube bent in U-shape, one end of which is connected to a point at where pressure is to be measured and other end remains opens to the atmosphere.
- The tube generally contains mercury or any other liquid whose specific gravity is greater than the specific gravity of the liquid whose pressure is to be measured.

### For gauge pressure

Let B is the point at which pressure is to be measured, whose value is P. the datum line is A-A

Let  $h_1$  = height of the liquid above datum line

$h_2$  = height of the heavy liquid above datum line

$S_1$  = sp. gr. Of light liquid

$S_2$  = sp. gr. Of heavy liquid

$\rho_1$  = density of light liquid =  $S_1 \times 1000$

$\rho_2$  = density of heavy liquid =  $S_2 \times 1000$

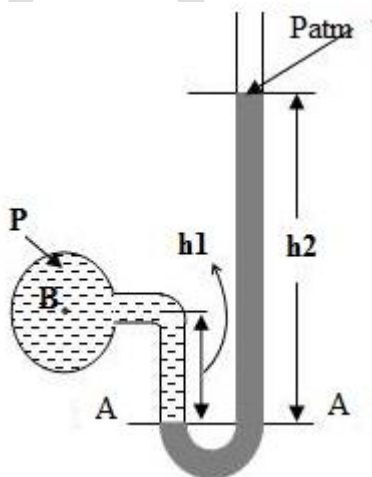

Pressure above datum in left limb =  $P + \rho_1 g h_1$

Pressure above datum in right limb =  $\rho_2 g h_2$

Equating the two pressures,  $P + \rho_1 g h_1 = \rho_2 g h_2$

$$P = \rho_2 g h_2 - \rho_1 g h_1$$

For vacuum pressure

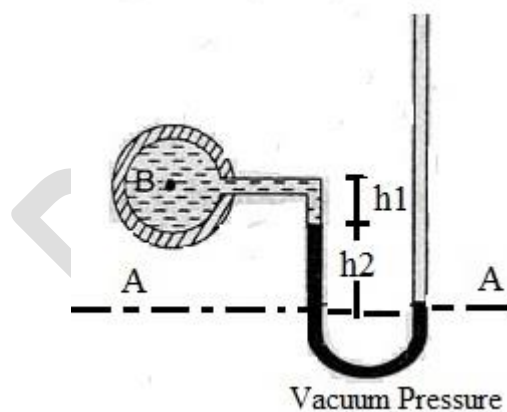

Pressure above datum in left limb =  $P + \rho_1 g h_1 + \rho_2 g h_2$

Pressure above datum in right limb = 0

Equating the two pressures,  $P + \rho_1 g h_1 + \rho_2 g h_2 = 0$

$$P = -(\rho_1 g h_1 + \rho_2 g h_2)$$

## DIFFERENTIAL MANOMETER

- Differential manometers are defined as the devices used for measuring the difference of pressure between two points in a pipe or in two different pipes.
- A differential manometer consists of a u-tube, containing a heavy liquid, whose two ends are connected to the points, whose pressure is to be measured.
- Most commonly types of differential manometers are-
  - (1) U-tube Differential manometer
  - (2) Inverted Differential manometer

## U-TUBE DIFFERENTIAL MANOMETER

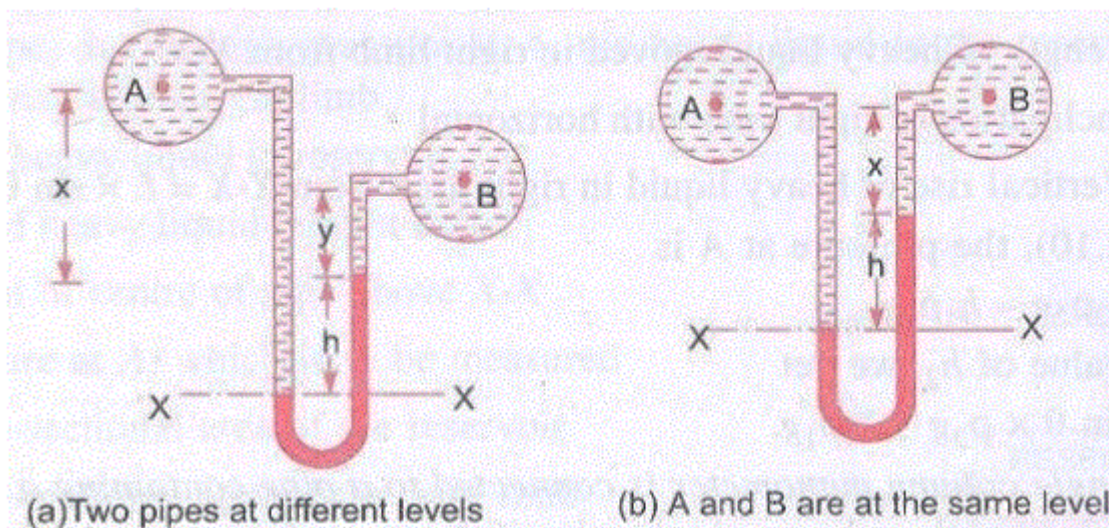

- (a) Let the two points A and B are at different level and also contains liquids of different sp.gr. these two points are connected to the differential manometer. Let the pressure at A and B are  $P_A$  and  $P_B$ .

$$P_A - P_B = h \times g (\rho_g - \rho_1) + \rho_2 g y - \rho_1 g x$$

- (b) Let the two points A and B are at same level and also contains differential manometer. Let the pressure at A and B are  $P_A$  and  $P_B$ .

$$P_A - P_B = h \times g (\rho_g - \rho_1)$$

### **PROBLEM**

The right limb of a simple u-tube manometer containing mercury is open to the atmosphere while the left limb is connected to a pipe in which a fluid of sp. gr. 0.9 is flowing. The centre of the pipe is 12 cm below the mercury in the right limb. Find the pressure of fluid in the pipe if the difference of mercury level in the two limbs is 20cm.

#### Solution

Sp.gr. of fluid,  $S_1 = 0.9$

Density of fluid ( $\rho_1$ ) =  $900 \text{ kg/m}^3$

Sp.gr. of mercury,  $S_2 = 13.6$

Density of mercury ( $\rho_2$ ) =  $13600 \text{ kg/m}^3$

Difference of mercury level  $h_2 = 20 \text{ cm} = 0.2 \text{ m}$

Height of fluid from A-A,  $h_1 = 20 - 12 = 8 \text{ cm} = 0.08 \text{ m}$

We know that pressure of fluid in pipe  $P = \rho_2 g h_2 - \rho_1 g h_1$

$$P = 13600 \times 9.81 \times 0.2 - 1000 \times 9.81 \times 0.08$$

$$= 26683 - 706 = 25977 \text{ N/m}^2 = 2.5977 \text{ N/cm}^2 \text{ (ans)}$$

### **2.4.1 BOURDON TUBE PRESSURE GAUGE**

The most common type of pressure gauge is a bourdon's tube pressure gauge. It is the simple in construction and is generally used for measuring high pressure.

A bourdon gauge uses a coiled tube, which as it expands due to pressure increase causes a rotation of an arm connected to the tube.

It consists of a hollow coiled metallic tube usually made of bronze or nickel as shown in fig. one end of the tube is sealed and other end is connected to the pipe whose pressure is to be measured. When the pressure in the hollow tube increases, the tube will tend to uncoil and when the pressure decreases it will tend to coil more tightly. This movement is transferred through a rack and pinion arrangement connected to a pointer over a calibrated dial, directly giving the pressure of fluid. This gauge is capable of measuring both positive and negative gauge pressure.





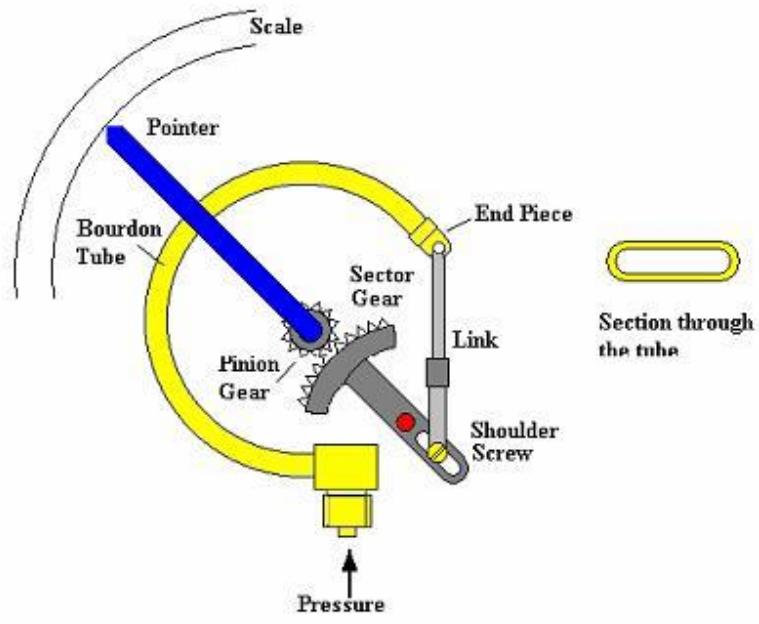

P.K.NATHAN

## **SHORT QUESTIONS**

### **1. Define manometer?**

Manometers are defined as the devices used for measuring the pressure in a fluid by balancing the column of fluid by the same or another column of the fluid. They are classified as:-

- (c) Simple manometer
- (d) Differential manometer

### **2. Define piezometer?**

Ans- It is the simplest form of manometer used for measuring gauge pressure. one end of this manometer is connected where pressure is to be measured and other end is opened to the atmosphere.

### **3. What is the use of differential manometer?**

Ans- differential manometer are used where difference of pressure is to be measured.

## **LONG QUESTIONS**

Q.1) Explain the working of bourdon tube pressure gauge. (2018-S)

Q.2) Explain absolute pressure, gauge pressure, vacuum pressure and their relationship through a plot. (2019-S)

Q.3) calculate the pressure due to a column of 0.5m of

(i) water

(ii) oil of specific gravity of 0.82

(iii) mercury.

Assume the density of water =  $1000\text{kg/m}^3$  (2019-S)

Q.4) a simple U-tube manometer containing mercury, the left limb is connected to a pipe in which a fluid of sp. gravity 0.8 is flowing. The centre of the pipe is 6cm below the level of mercury in right limb. Find the pressure of fluid in pipe if difference of mercury level in two limbs is 18cm. (2019-S)

P.K.NATH SR

## CHAPTER-03

### HYDROSTATICS

#### 3.1 HYDROSTATIC PRESSURE

- Hydrostatics is the branch of fluid mechanics which deals with the study of fluid at rest.
- This means that there will be no relative motion between the adjacent or neighbouring fluid layers.
- There is no shear stress acting on the fluid.
- Then the forces acting on the fluid particle will be –
  1. Due to pressure of fluid normal to the surface
  2. Due to gravity.

#### 3.2 TOTAL PRESSURE AND CENTRE OF PRESURE

**Total pressure** is defined as the force exerted by a static fluid on a surface either plane or curved when the fluid comes in contact with the surfaces. This force always acts normal to the surface.

- **Centre of pressure** is defined as the point of application of total pressure on the surface.
- There are four cases of submerged surface on which the total pressure force and centre of pressure is to be determined. The submerged surfaces may be:
  - (1) Vertical plane surface
  - (2) Horizontal plane surface
  - (3) Inclined plane surface
  - (4) Curved plane surface

## VERTICAL PLANE SURFACE SUBMERGED IN LIQUID

Consider a plane vertical surface of arbitrary shape immersed in a liquid as shown in fig.

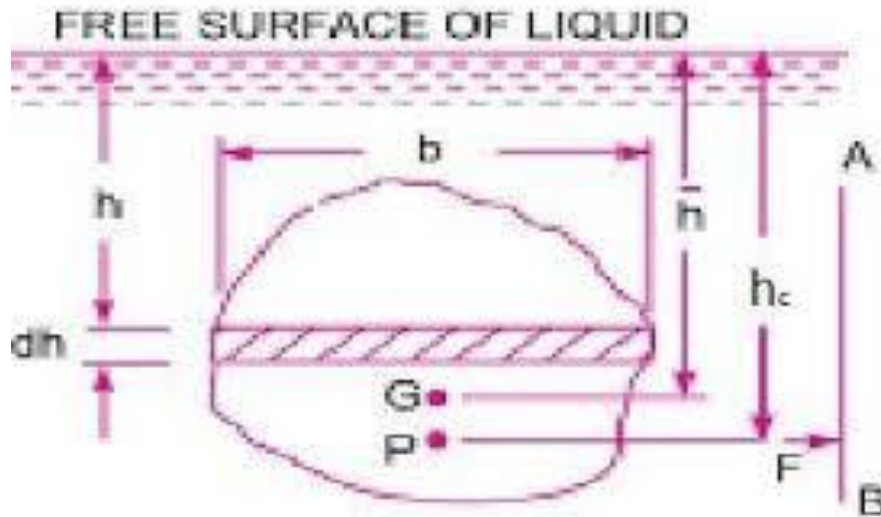

Let  $A$  = total area of the surface

$\bar{h}$  = distance of C.G of the area from the free surface of liquid

$G$  = centre of gravity of plane surface

$P$  = centre of pressure

$h^x$  = distance of centre of the pressure from the free surface of liquid.

total pressure ( $F$ ) =  $\rho g A \bar{h}$

centre of pressure,  $h^x = (I_G / A \bar{h}) + \bar{h}$

### **3.1 PROBLEM**

A rectangular plane surface is 2 m wide and 3 m deep. It lies in vertical plane in water. Determine the total pressure and position of centre of pressure on the plane surface when its upper edge is horizontal and (a) coincides with water surface (b) 2.5 m below the free surface.

#### Solution

Width of plane surface,  $b = 2\text{ m}$

Depth of plane surface,  $d = 3\text{ m}$

(a) Upper edge coincides with water surface

$$\begin{aligned}\text{Total pressure force (F)} &= \rho g A \bar{h} \\ &= 1000 \times 9.81 \times (3 \times 2) \times (3/2) \\ &= 88290 \text{ N (ans)}\end{aligned}$$

#### Centre of pressure

$$I_G = bd^3/12 = 2 \times 3^3/12 = 4.5 \text{ m}^4$$

$$\begin{aligned}h^x &= (I_G / A \bar{h}) + \bar{h} \\ &= 4.5 / (6 \times 1.5) + 1.5 = 2.0 \text{ m (ans)}\end{aligned}$$

(b) Upper edge is 2.5 m below water surface

$$\begin{aligned}\text{Total pressure force (F)} &= \rho g A \bar{h} \\ &= 1000 \times 9.81 \times (3 \times 2) \times (4.0) \\ &= 235440 \text{ N (ans)}\end{aligned}$$

#### Centre of pressure

$$I_G = 4.5, A = 6, \bar{h} = 4.0$$

$$\begin{aligned}h^x &= (I_G / A \bar{h}) + \bar{h} \\ &= 4.5 / (4.5 \times 6.0) + 4.0 = 4.1875 \text{ m (ans)}\end{aligned}$$

### **3.4 BUOYANCY:**

When a body is immersed in a liquid, an upward force is exerted by the fluid on the body. This upward force is equal to the weight of the fluid displaced by the body and is called force of buoyancy or simply buoyancy.

## **CENTRE OF BUOYANCY**

- It is defined as the point through which force of buoyancy is supposed to act.
- As the force of buoyancy is a vertical force and equal to the weight of the fluid displaced by the body, the centre of buoyancy will be the centre of gravity of displaced liquid.



## **3.4 ARCHIMEDES PRINCIPLE**

It states that “The upward buoyant force that is exerted on a body immersed in a fluid, whether partially or fully submerged, is equal to the weight of the fluid that the body displaces and acts in the upward direction at the centre of mass of the displaced fluid”.

## **METACENTRE**

- It is defined as the point about which a body starts oscillating when a body is tilted by a small angle.
- The meta-centre may also be defined as the point at which the line of action of the force of buoyancy will meet the normal axis of the body when the body is given a small angular displacement.

## **3.4 METACENTRIC HEIGHT**

The distance between the centre of gravity and the metacentre of a floating body, as of a vessel. Thus metacentric height is equal to the distance between G and M.

## PROBLEM

A rectangular pontoon is 5 m long, 3 m wide and 1.20 m high. The depth of immersion of the pontoon is 0.80 m in sea water. If the centre of gravity is 0.6 m above the bottom of the pontoon, determine the meta centric height. The density for sea water = 1025 kg/m<sup>3</sup>.

## Solution

Dimension of pontoon = 5m × 3m × 1.20m

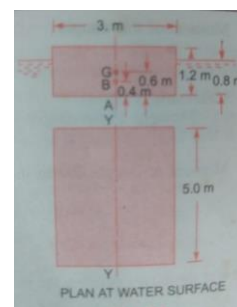

Depth of immersion = 0.8m

Distance AG = 0.6 m

Distance AB =  $\frac{1}{2} \times \text{depth of immersion}$   
 $= \frac{1}{2} \times 0.8 = 0.4\text{m}$

Density of sea water = 1025 kg/m<sup>3</sup>

Meta-centre height GM, given by  $GM = \frac{I}{V} - BG$

$$I = \frac{1}{12} \times 5 \times 3^3 = \frac{45}{4} \text{ m}^4$$

V = volume of the body submerged in water

$$= 3 \times 0.8 \times 5.0 = 12 \text{ m}^3$$

BG = AG - AB = 0.6 - 0.4 = 0.2m

$$GM = \left(\frac{45}{4}\right) \times \left(\frac{1}{12}\right) - 0.2 = 0.7375\text{m (ans)}$$



### 3.5 CONCEPT OF FLOATATION

- A submerged body is said to be stable if it comes back to its original position after a slight disturbance.
- The relative position of the centre of gravity and centre of buoyancy of the body determines the stability of a submerged body.

#### STABILITY OF A FLOATING BODY

The position of centre of gravity and centre of buoyancy in case of a completely submerged body are fixed. Consider a balloon, which is completely submerged in air. Let the lower portion of the balloon contains heavier material, so that its centre of the gravity is lower than its centre of buoyancy as shown in fig.

Let the weight of the balloon is  $W$ . the weight  $W$  is acting through  $G$ , vertically in the downward direction, while the buoyancy force  $F_b$  is acting vertically up, through  $B$ . for equilibrium of the balloon  $W = F_b$ , if the balloon is given an angular displacement in clock wise direction as shown in fig. (A), then  $W$  and  $F_b$  constitute a couple acting in the anti-clock wise direction and brings the balloon in original position. Thus the balloon in the position as shown in fig (a) is in stable equilibrium.

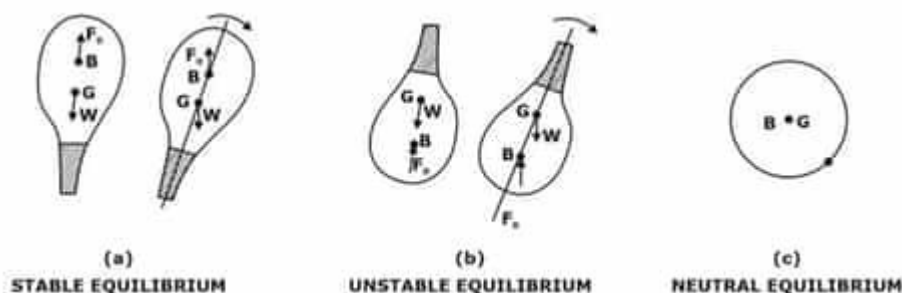

**(a) Stable equilibrium:** when  $W = F_b$  and point  $B$  is above  $G$ , the body is said to be in stable equilibrium.

- (b) **Unstable equilibrium:** if  $W = F_B$ , but the centre of buoyancy (B) is below the centre of gravity (G) the body is in unstable equilibrium:
- (c) **Neutral equilibrium:** if  $W = F_B$ , and B and G are at the same point, as shown in fig. C the body is said to be neutral equilibrium.

### SHORT QUESTIONS

#### Q-1) State Archimedes principle. (2018-S, 2019-S)

It states that “The upward buoyant force that is exerted on a body immersed in a fluid, whether partially or fully submerged, is equal to the weight of the fluid that the body displaces and acts in the upward direction at the centre of mass of the displaced fluid”.

#### Q-2) Define buoyancy and metacentric height. (2019-S)

**buoyancy** -When a body is immersed in a liquid, an upward force is exerted by the fluid on the body. This upward force is equal to the weight of the fluid displaced by the body and is called force of buoyancy or simply buoyancy.

**metacentric height**- The distance between the centre of gravity and the metacentre of a floating body, as of a vessel. Thus metacentric height is equal to the distance between G and M.

## LONG QUESTIONS

**Q-1) A rectangular plane surface is 4m wide and 6m deep. It lies in vertical plane in water. Determine the total pressure and position of centre of pressure on the plane surface when its upper edge is horizontal and-**

- (i) Coincides with water surface**
- (ii) 2.5m below the water surface. (2018-S)**

**Q-2) explain briefly about stable, unstable and neutral equilibrium of floating. (2019-S)**

**Q-3) A Rectangular plate 3m long and 1m wide is immersed vertically in water in such a way that its 3m side is parallel to the water surface and is 1m below it. Calculate (i) total pressure on plate (ii) position of centre of pressure. (2019-S)**

**Q-4) A block of wood of specific gravity 0.8 floats in water. Determine the metacentric height of block if its size is 4m×2m×1.6m. (2019-S)**

## **CHAPTER-04**

### **KINEMATIC OF FLOW**

#### **Introduction**

Kinematics of flow is the branch of fluid mechanics which deals with the study of fluid motion without consideration of any forces causing motion is called fluid kinematics.

#### **4.1 TYPES OF FLOW**

Fluid flows are classified as:

- (1) Steady and unsteady flow
- (2) Uniform and non-uniform flow
- (3) Laminar and turbulent flow
- (4) Compressible and incompressible flow
- (5) Rotational and irrotational flow
- (6) Ideal and real flow
- (7) One, two and three dimensional flow

#### **STEADY AND UNSTEADY FLOW**

- Steady flow is that type of flow in which fluid parameters (velocity, pressure, density, etc.) at any point in fluid flow field do not change with respect to time.
- Mathematically,
$$(\Delta V/\Delta t)_{x,y,z} = (\Delta P/\Delta t)_{x,y,z} = (\Delta \rho/\Delta t)_{x,y,z} = 0$$
- Unsteady flow is that type of flow in which fluid parameters (velocity, pressure, density, etc.) at any point in fluid flow field changes with respect to time.
- Mathematically,

$$(\Delta V/\Delta t)_{x,y,z} \neq 0 \quad (\Delta P/\Delta t)_{x,y,z} \neq 0 \quad (\Delta \rho/\Delta t)_{x,y,z} \neq 0$$

### UNIFORM AND NON-UNIFORM FLOW

➤ Uniform flow is that type of flow in which the velocity at any given time does not change with respect to space.

➤ mathematically

$$(\Delta V/\Delta S)_{t = \text{constant}} = 0$$

➤ Non-Uniform flow is that type of flow in which the velocity at any given time does not change with respect to space.

➤ mathematically

$$(\Delta V/\Delta S)_{t = \text{constant}} \neq 0$$

### LAMINAR AND TURBULENT FLOW

➤ laminar flow is defined as that type of flow in which the fluid particles move along well-defined paths or stream line and all the stream lines are straight and parallel.

➤ Turbulent flow is defined as that type of flow in which the fluid particles moves in a zigzag way

➤ If the Reynolds number is less than 2000, the flow is called laminar and if the Reynolds number is more than 4000 then the flow is turbulent, and if the Reynolds number is in between 2000 to 4000 the flow is either laminar or turbulent.

### COMPRESSIBLE AND INCOMPRESSIBLE FLOW

➤ Compressible flow is that type of flow in which the density of fluid changes from point to point or in other words density is not constant for the fluid.

- Compressible flow is that type of flow in which the density of fluid do not change from point to point or in other words density is constant for the fluid.

### **ROTATIONAL AND IRROTATIONAL FLOW**

- Rotational flow is that types of flow in which the fluid particle while in moving along stream line also rotate about their own axis.
- Irrotational flow is that types of flow in which the fluid particle while in moving along stream line do not rotate about their own axis.

### **RATE OF FLOW OR DISCHARGE (Q)**

- It is defined as the quantity of fluid flowing per second through a section of a pipe or a channel is called rate of flow or discharge.
- For an incompressible fluid (liquid) the rate of discharge is expressed as the volume of fluid flowing across the section per second.
- For compressible fluid (gas) the rate of discharge is expressed as the weight of fluid flowing across the section per second.

Consider a liquid flowing through a pipe in which

A = cross- sectional area of pipe

V = average velocity of fluid across the sectional

Then discharge  $Q = A \times V$

### **4.2 CONTINUITY EQUATION**

It states that “the mass of a fluid passing through different cross-section of a pipe, and its flow is same if no fluid is added or removed from the pipe”.

Consider two cross section of a pipe as shown in fig.

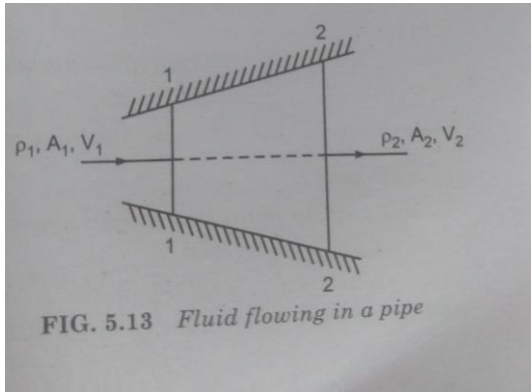

Let,  $V_1$  = average velocity at cross-section 1-1

$A_1$  = area at section 1-1

$\rho_1$  = density of fluid at section 1-1

$V_2$  = average velocity at cross-section 2-2

$A_2$  = area at section 2-2

$\rho_2$  = density of fluid at section 2-2

then the rate of flow in section 1-1 =  $\rho_1 A_1 V_1$

rate of flow in section 2-2 =  $\rho_2 A_2 V_2$

according to conservation of mass

Rate of flow at section 1-1 = rate of flow at section 2-2

$$\rho_1 A_1 V_1 = \rho_2 A_2 V_2$$

if the fluid is incompressible than  $\rho_1 = \rho_2$  and continuity equation reduces to  $A_1 V_1 = A_2 V_2$

## 4.3 BERNOULLI'S THEOREM

It states "in an ideal incompressible fluid when the flow is steady and continuous then the sum of potential energy, kinetic energy and pressure energy is constant along a stream line".

Mathematically

$$(P/\rho g) + (V^2/2g) + Z = \text{constant}$$

### Proof

Consider an incompressible liquid is flowing through a non-uniform pipe as shown in fig. consider two sections AA and BB of the pipe. Let the pipe is running full and there is a continuity of flow between the two sections.

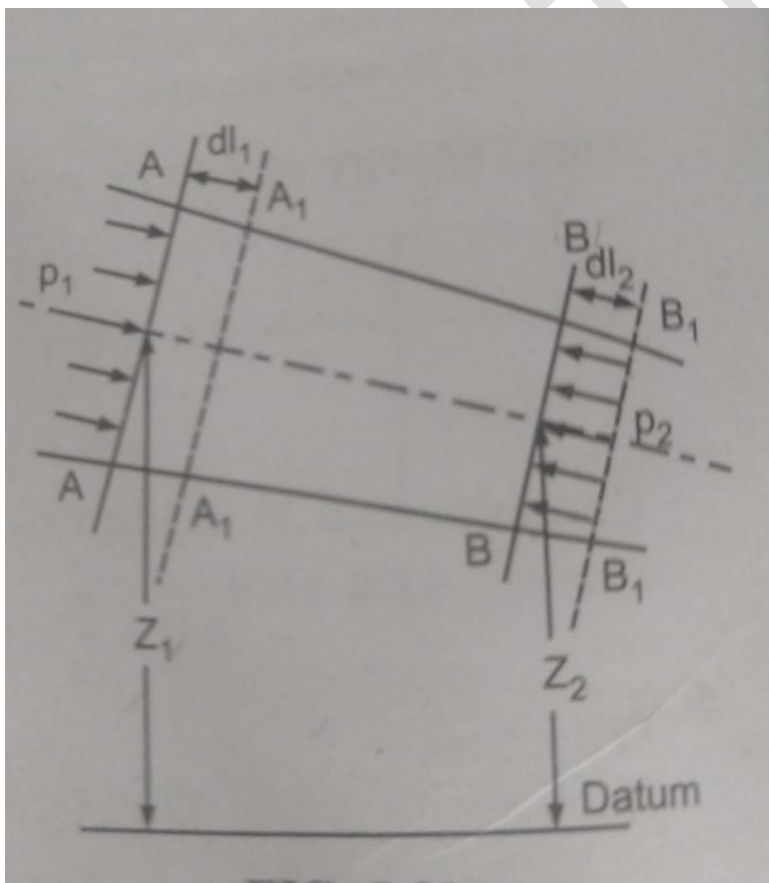

Let  $Z_1$ ,  $P_1$ ,  $V_1$  and  $A_1$  be the height above datum, pressure intensity, velocity and area of pipe respectively at section A.A.



Let  $Z$ ,  $P$ ,  $V$  and  $A$  be the corresponding quantities at section BB. let the liquid between the section AA and BB moves to position  $A_1A_1$  and  $B_1B_1$  in an infinitely small interval of time.

Let  $W$  be the weight of liquid between AA and  $A_1 A_1$  or BB and  $B_1B_1$ .

As the flow is continuous

$$W = (A_1 dl_1) w = (A_2 dl_2) w$$

Where  $w$  = sp. weight of fluid.

$$(A_1 dl_1) w = W \quad \therefore (A_1 dl_1) = W/w \quad \dots\dots(1)$$

$$(A_2 dl_2) w = W \quad \therefore (A_2 dl_2) = W/w \quad \dots\dots(2)$$

From equation (1) and (2)

$$\text{We get } (A_1 dl_1) = (A_2 dl_2) = W/w$$

Work-done by the pressure at AA is moving the liquid to  $A_1 A_1$

$$= \text{force} \times \text{distance} = (P_1 A_1) \times dl_1 = P_1 A_1 dl_1$$

Similarly, work done by the pressure at BB in moving the liquid to

$$B_1B_1 = - P_2 A_2 dl_2$$

(Minus sign shows that the direction of  $P_2$  is opposite to  $P_1$ )

Total work done by pressure

$$= P_1 A_1 dl_1 - P_2 A_2 dl_2$$

$$= P_1 \times (W/w) - P_2 \times (W/w)$$

$$= (W/w) \times (P_1 - P_2)$$

$$\text{Loss of potential energy} = WZ_1 - WZ_2 = W(Z_1 - Z_2)$$

$$\text{Gain in kinetic energy} = W/2g(V_2^2 - V_1^2)$$

We know that,

Loss of potential energy + work done by pressure = gain in kinetic energy

$$W(Z_1 - Z_2) + (W/w) \times (P_1 - P_2) = W/2g(V_2^2 - V_1^2)$$

$$(Z_1 - Z_2) + 1/w (P_1 - P_2) = 1/2g(V_2^2 - V_1^2)$$

$$Z_1 - Z_2 + P_1/w - P_2/w = V_2^2/2g - V_1^2/2g$$

$$Z_1 + V_1^2/2g + P_1/w = Z_2 + V_2^2/2g + P_2/w$$

i.e. the sum of potential head, kinetic head and pressure head is constant.

### 4.3 VENTURI METER

A venturi meter is a device used for measuring the rate of a flow a fluid flowing through a pipe. It consists of three parts:

- (1) A short converging part
- (2) Throat
- (3) Diverging part

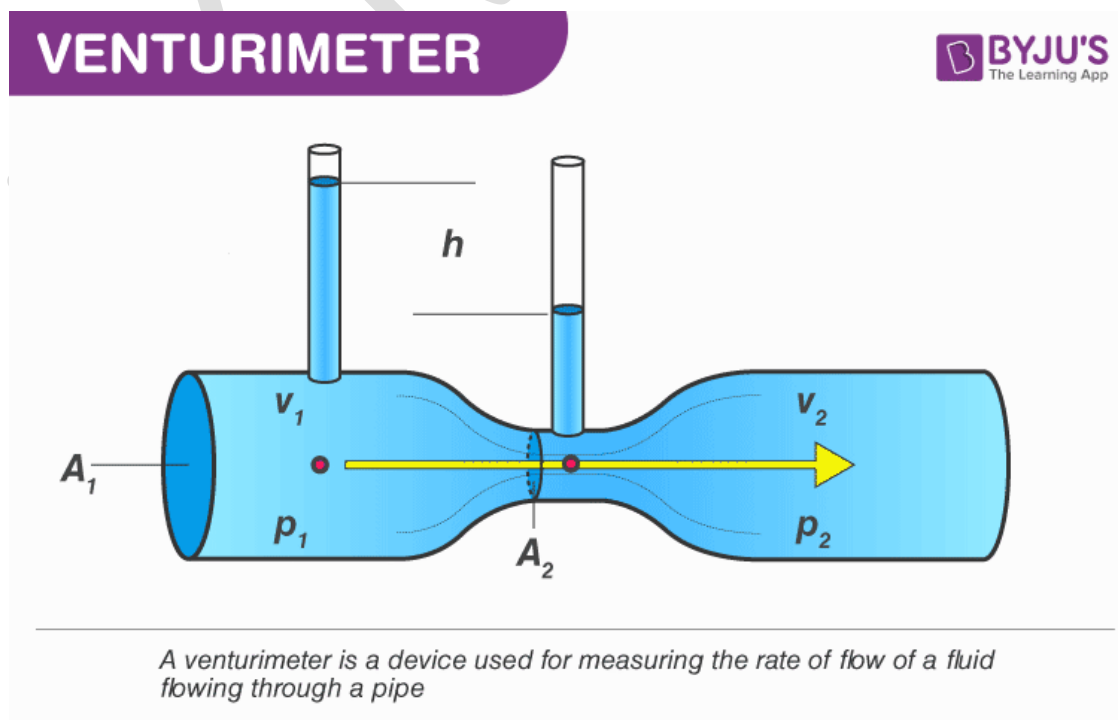

### Discharge through venturi-meter

$$Q_{act} = C_d \frac{a_1 a_2}{\sqrt{a_1^2 - a_2^2}} \sqrt{2gh}$$

Where,  $C_d$  = coefficient of discharge

$A_1$  = area at inlet

$A_2$  = area at throat

$h$  = difference in liquid level

### 4.3 PITOT TUBE

It is a device used for measuring the velocity of flow at any point in a pipe or a channel.

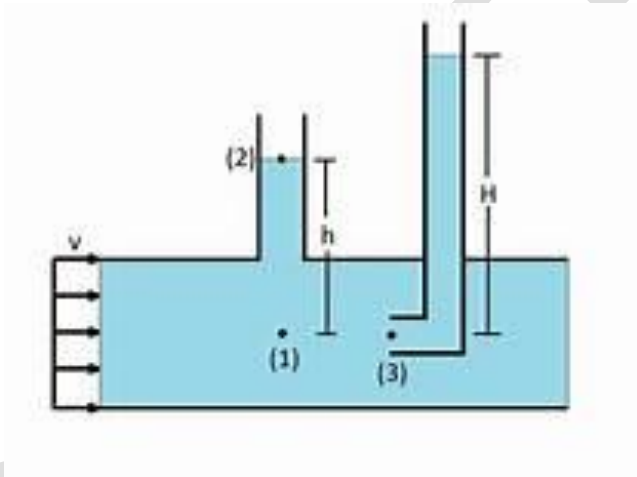

$$\text{Velocity of flow (V)} = \sqrt{2g(H - h)}$$

#### Problem

A pipe of diameter 400mm carries water at a velocity of 25m/s. the pressure at the points A and B are given as 29.43N/cm<sup>2</sup> and 22.563 N/cm<sup>2</sup> respectively while the datum head at A and B are 28m and 30 m. find the loss of head between A and B.

### Solution

Dia of pipe,  $D = 400\text{mm} = 0.4 \text{ m}$

Velocity,  $V = 25 \text{ m/s}$

$P_A = 28 \text{ m}$

$V_A = v = 25 \text{ m/s}$

$$\begin{aligned}\text{Total energy at A, } E_A &= Z_A + V_A^2/2g + P_A/w \\ &= 28 + (25^2/2 \times 9.81) + 29.43 \times 10^4 / (1000 \times 9.81) \\ &= 89.85 \text{ m}\end{aligned}$$

At point B,  $P_B = 22.563 \text{ N/cm}^2 = 22.563 \times 10^4 \text{ N/cm}^2$

$Z_B = 30\text{m}$

$V_B = V = V_A = 25 \text{ m/s}$

Total energy at B,

$$\begin{aligned}E_B &= (P_B/\rho g) + (V_B^2/2g) + Z_B \\ &= 22.563 \times 10^4 / (1000 \times 9.81) + 25^2 / (2 \times 9.81) + 30 \\ &= 84.85 \text{ m}\end{aligned}$$

$$\text{Loss of energy} = E_A - E_B = 89.85 - 84.85 = 5.0 \text{ m (ans)}$$

### Problem

A horizontal venturi meter with inlet and outlet diameters 30cm and 15 cm respectively is used to measure the flow of water. The reading of differential manometer connected to the inlet and the throat is 20 cm of mercury. Determine the rate of flow. Take  $C_d = 0.98$ .

### Solution

Dia at inlet  $d_1 = 30\text{cm}$

Area at inlet  $a_1 = \pi/4 d_1^2 = 706.85 \text{ cm}^2$

Dia at throat  $d_2 = 15 \text{ cm}$

Area at throat  $a_2 = \pi/4 d_2^2 = 176.7 \text{ cm}^2$

$C_d = 0.98$

Reading of differential manometer =  $x = 20$  cm of mercury

Difference of pressure head,  $h = x (S_h/S_o - 1) = 252$  cm of water

$$Q_{act} = C_d \frac{a_1 a_2}{\sqrt{a_1^2 - a_2^2}} \sqrt{2gh}$$

= 125.756 lit/s

### SHORT QUESTIONS

**Q.1) Define uniform and laminar flow. 2018-S**

**Ans- Uniform flow** is that type of flow in which the velocity at any given time does not change with respect to space.

mathematically

$$(\Delta V / \Delta S)_{t = \text{constant}} = 0$$

**laminar flow** is defined as that type of flow in which the fluid particles move along well-defined paths or stream line and all the stream lines are straight and parallel.

**Q.2) Define about non uniform flow and turbulent flow. 2019-S**

**Non-Uniform flow** is that type of flow in which the velocity at any given time does not change with respect to space.

mathematically

$$(\Delta V / \Delta S)_{t = \text{constant}} \neq 0$$

**Turbulent flow** is defined as that type of flow in which the fluid particles moves in a zigzag way

**Q.3) what is the difference between laminar flow and turbulent flow. 2019-S**

laminar flow is defined as that type of flow in which the fluid particles move along well-defined paths or stream line and all the stream lines are straight and parallel.

Turbulent flow is defined as that type of flow in which the fluid particles moves in a zigzag way

If the Reynolds number is less than 2000, the flow is called laminar and if the Reynolds number is more than 4000 then the flow is turbulent, and if the Reynolds number is in between 2000 to 4000 the flow is either laminar or turbulent.

**Q.4) what is the function of venturimeter.2019-S**

**Venturi meter** Is a device used to measure the rate of flow or discharge in a pipe.

### LONG QUESTION

**Q.1) State continuity equation and prove it for one dimensional flow. (2018-S)**

**Q.2) water is flowing through a pipe having diameter 300mm and 200mm at bottom and upper end respectively. The intensity of pressure at bottom end is  $24.525 \text{ N/cm}^2$  and the pressure at the upper end is  $9.81 \text{ N/cm}^2$ , determine the difference in datum head if the rate of flow through the pipe is 40lit/sec. (2018-S)**

**Q.3) Water flows through a 300mm x 150mm horizontal venturi meter at the rate of  $0.04 \text{ m}^3/\text{sec}$ . A differential manometer with gauge liquid of specific gravity of 1.25 indicates a deflection of 1.05m. calculate the coefficient of discharge for the venturi meter. (2019-S)**

**Q.4) What Is pitot tube. Why it is used. Derive an expression for velocity of liquid flow at any point in a pipe by using pitot tube. (2019-S)**

## CHAPTER-05

### ORIFICES, NOTCHES & WEIRS

#### 5.1-ORIFICE

- Orifice is a small opening of any cross-section (such as circular, triangular, rectangular etc.) on the side or at the bottom of a tank, through which a fluid is flowing.
- It is used for measuring the rate of flow or discharge.

#### Classification of orifices

The orifices are classified on the basis of their size, shape, nature of discharge and shape of the upstream edge. The following are the important classifications-

- (1) The orifices are classified as small orifice or large orifice depending upon the size of the orifice and head of liquid from the centre of the orifice. If the head of liquid from the centre of orifice is more than five times the depth of orifice, the orifice is called small orifice. And if the head of the liquids is less than five times the depth of orifice, it is known as large orifice
- (2) The orifices are classified as (i) circular orifices, (ii) triangular orifices, (iii) rectangular orifices (iv) square orifices depending upon their cross-sectional areas.
- (3) The orifices are classified as (i) sharp edged orifice, (ii) bell-mouthed orifice depending upon the upstream edge of the orifices.
- (4) The orifices are classified as (i) free discharging orifices and (ii) drowned or submerged orifices depending upon the nature of discharge.

The sub-merged orifices are further classified as (a) fully sub-merged orifices and (b) partially sub-merged orifices.



## FLOW THROUGH AN ORIFICE

Consider a tank fitted with a circular orifice in one of its sides as shown in fig. let H be the head of liquid above the centre of the orifice. The liquid flowing through the orifice forms a jet of liquid whose area of cross-section is less than that of orifice. The area of jet of fluid goes on decreasing and at a section CC, the area is minimum. This section is called vena-contracta. Beyond this section the jet diverges and is attracted to the downward direction by the gravity.

Consider two points 1 and 2 as shown in figure. Point 1 is inside the tank and point 2 is vena-contracta.

Let the flow is steady and at a constant head H. by applying Bernoulli's equation at point 1 and 2.

$$Z_1 + V_1^2/2g + P_1/w = Z_2 + V_2^2/2g + P_2/w$$

But,  $Z_1 = Z_2$

$$V_1^2/2g + P_1/w = V_2^2/2g + P_2/w$$

Now,  $P_1/w = H$

$$P_2/w = 0 \text{ (atmospheric)}$$

$V_1$  is very small in comparison to  $V_2$  as the area of the tank is very large as compared to the area of the jet of the liquid.

$$H + 0 = 0 + V_2^2/2g$$

$$V_2 = \sqrt{2gH}$$

This is the theoretical velocity. Actual velocity will be less than this value.

## ORIFICE CO-EFFICIENTS

The hydraulic coefficient's are-

- (1) co-efficient of velocity,  $C_v$
- (2) co-efficient of contraction,  $C_c$
- (3) co-efficient of discharge,  $C_d$

### CO-EFFICIENT OF VELOCITY, $C_v$

- It is defined as the ratio between actual velocity of a jet of liquid at vena-contracta to the theoretical velocity of jet.
- It is denoted by  $C_v$ .

Mathematically

$C_v$  = actual velocity of jet at vena- contracta / theoretical velocity

$$= V / \sqrt{2gH}$$

Where,  $V$  = actual velocity

$\sqrt{2gH}$  = theoretical velocity

The value of  $C_v$  varies from 0.95 to 0.99.

### CO-EFFICIENT OF CONTRACTION, $C_c$

- It is defined as the ratio of the area of the jet at vena-contracta to the area of orifice.
- It is denoted by  $C_c$ .
- Let  $a$  = area of orifice

$a_c$  = area of jet at vena-contracta

then,  $C_c$  = area of jet at vena-contracta / area of orifice

$$= a_c / a$$

The value of  $C_c$  varies from 0.61 to 0.69 depending upon the shape and size of orifice.

## CO-EFFICIENT OF DISCHARGE, $C_d$

➤ It is defined as the ratio between the actual discharge from an orifice to the theoretical discharge from an orifice.

➤ It is denoted by  $C_d$ .

➤ Mathematically,  $C_d = Q/Q_{th}$

$C_d = \text{actual area} \times \text{actual velocity} / (\text{theoretical area} \times \text{theoretical velocity})$

$= (\text{actual area}/\text{theoretical area}) \times (\text{actual velocity} / \text{theoretical velocity})$

$$C_d = C_v \times C_c$$

The value of  $C_d$  varies from 0.61 to 0.65.

## NOTCHES AND WEIRS

➤ **A notch** is a device used for measuring the rate of flow of a liquid through a small channel or a tank.

➤ It may be defined as an opening in the side of a tank or a small channel in such a way that the liquid surface in the tank or channel is below the top edge of the opening.

➤ **A weir** is a concrete or masonry structure, placed in an open channel over which the flow occurs. It is generally in the form of vertical wall, with a sharp edge at the top, running all the way across the open channel.

➤ The notch is of small size while weir is a bigger size. Notch generally made of metallic plate while the weir is made of concrete or masonry structure.

## **5.4 CLASSIFICATION OF NOTCHES AND WEIRS**

The notches are classified as:

- (1) According to the shape of the opening:
  - a. Rectangular notch
  - b. Triangular notch
  - c. Trapezoidal notch
  - d. Stepped notch
- (2) According to the effect of the sides of the nappe:
  - a. Notch with end concentration.
  - b. Notch without end concentration.

Weirs are classified as follows:

- (1) According to the shape of the opening
  - a. Rectangular weir
  - b. Triangular weir
  - c. Trapezoidal weir
- (2 ) According to the shape of the crest:
  - a. Sharp crested weir
  - b. Broad crested weir
  - c. Narrow crested weir
  - d. Ogee shaped weir
- (3 ) According to the effect of sides on the emerging nappe.
  - a. Weir with end contraction
  - b. Weir without end concentration

## 5.5 DISCHARGE OVER RECTANGULAR NOTCH OR WEIR

The discharge over rectangular notch and weir is the same.

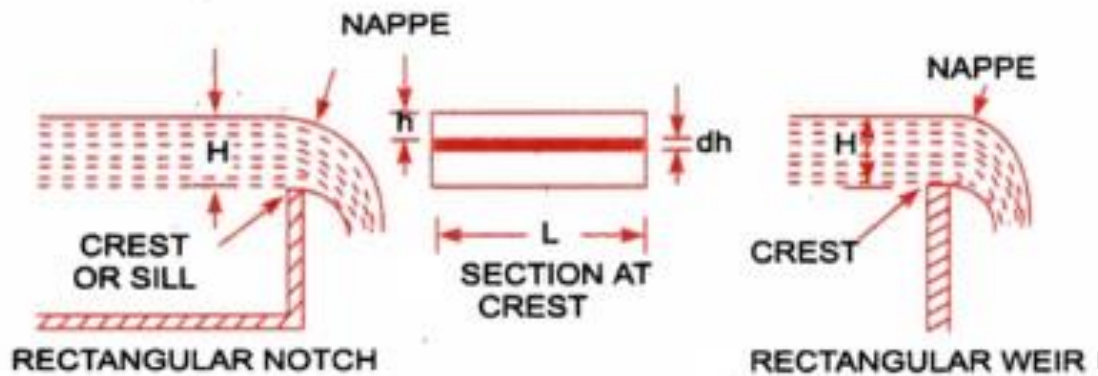

Now, let us consider that we have channel carrying water and let us think a rectangular notch or weir with this channel as displayed here in above figure.

We have following data from above figure and these data are as mentioned here.

$H$  = Head of water over the crest

$L$  = Length of the rectangular notch or weir

Let us consider one elementary horizontal strip of water of thickness  $dh$  and length  $L$  as displayed in above figure.

$dh$  = Thickness of elementary horizontal strip of water flowing over the rectangular notch or weir

$h$  = Depth of elementary horizontal strip of water flowing over the rectangular notch or weir

$C_d$  = Co-efficient of discharge

Area of elementary horizontal strip of water =  $L \times dh$

We will determine the value of discharge  $dQ$  through the elementary horizontal strip of water. After securing the expression for discharge through the elementary horizontal strip, we will integrate the expression between the limit 0 to  $H$  and we will have the expression for the discharge over a rectangular notch or weir.

$$dQ = C_d \times \text{Area of strip} \times \text{Theoretical velocity}$$

$$= C_d \times L \times dh \times \sqrt{2gh}$$

**Total discharge i.e. Q over a rectangular notch or weir**

$$Q = \int_0^H C_d \cdot L \cdot \sqrt{2gh} \cdot dh = C_d \times L \times \sqrt{2g} \int_0^H h^{1/2} dh$$

$$= C_d \times L \times \sqrt{2g} \left[ \frac{h^{1/2+1}}{\frac{1}{2}+1} \right]_0^H = C_d \times L \times \sqrt{2g} \left[ \frac{h^{3/2}}{3/2} \right]_0^H$$

$$= \frac{2}{3} C_d \times L \times \sqrt{2g} [H]^{3/2}$$

### **5.6 DISCHARGE OVER TRINGULAR NOTCH OR WEIR**

The expression of the discharge over a triangular notch or over a weir will be same.

Now, let us consider that we have channel carrying water and let us think a triangular notch or weir with this channel as displayed here in following figure.

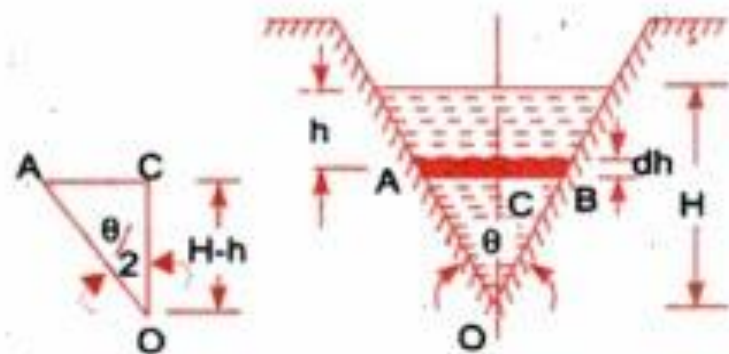

We have following data from above figure and these data are as mentioned here

H = Head of water above the V-notch

$\theta$  = Angle of notch

Let us consider one elementary horizontal strip of water of thickness  $dh$  and at a depth of  $h$  from free surface of water as displayed here in above figure.

$dh$  = Thickness of elementary horizontal strip of water flowing over the triangular notch or weir

$h$  = Depth of elementary horizontal strip of water from free surface of water

$C_d$  = Co-efficient of discharge

We will determine the value of discharge  $dQ$  through the elementary horizontal strip of water. After securing the expression for discharge through the elementary horizontal strip, we will integrate the expression between the limit 0 to  $H$  and we will have the expression for the discharge over entire triangular notch or weir.

$dQ = C_d \times \text{Area of strip} \times \text{Theoretical velocity}$

### Area of strip

First we will secure the value of area of horizontal elementary strip

$$\tan \frac{\theta}{2} = \frac{AC}{OC} = \frac{AC}{(H-h)}$$

$$AC = (H-h) \tan \frac{\theta}{2}$$

$$\text{Width of strip} = AB = 2AC = 2(H-h) \tan \frac{\theta}{2}$$

$$\text{Area of strip} = 2(H-h) \tan \frac{\theta}{2} \times dh$$

Now we will secure here the expression for

$$= 2 \times C_d \times \tan \frac{\theta}{2} \times \sqrt{2g} \left[ \frac{2}{3} H \cdot H^{3/2} - \frac{2}{5} H^{5/2} \right]$$

$$= 2 \times C_d \times \tan \frac{\theta}{2} \times \sqrt{2g} \left[ \frac{2}{3} H^{5/2} - \frac{2}{5} H^{5/2} \right]$$

$$= 2 \times C_d \times \tan \frac{\theta}{2} \times \sqrt{2g} \left[ \frac{4}{15} H^{5/2} \right]$$

$$= \frac{8}{15} C_d \times \tan \frac{\theta}{2} \times \sqrt{2g} \times H^{5/2}$$

For a right-angled V-notch, if  $C_d = 0.6$

$$\theta = 90^\circ, \quad \therefore \tan \frac{\theta}{2} = 1$$

Discharge

$$Q = \frac{8}{15} \times 0.6 \times 1 \times \sqrt{2 \times 9.81} \times H^{5/2}$$

$$= 1.417 H^{5/2}$$

## 5.7 PROBLEM

The head of water over an orifice of diameter 100mm is 10m. the water is coming out from the orifice is collected in a circular tank of diameter 1.5m. the rise of water level in this tank is 1.0m in 25 seconds. Also the co-ordinates of a point on the jet, measured from vena-contracta are 4.3m horizontal and 0.5m vertical. Find the coefficients,  $C_d$ ,  $C_v$ ,  $C_c$ .

Solution

Data given

Head,  $H = 10\text{m}$

Dia of orifice,  $d = 100 \text{ mm} = 0.1\text{m}$

Area of orifice,  $a = 0.007853 \text{ m}^2$



Dia of measuring tank,  $D = 1.5 \text{ m}$

Area of the tank,  $A = 1.767 \text{ m}^2$

Rise of water level,  $h = 1 \text{ m}$

In time = 25 sec

Horizontal distance,  $x = 4.3 \text{ m}$

Vertical distance,  $y = 0.5 \text{ m}$

Now theoretical velocity,  $V_{th} = \sqrt{2gH} = \sqrt{2 \times 9.81 \times 10} = 14 \text{ m/s}$

Theoretical discharge,  $Q_{th} = V_{th} \times \text{area of orifice}$

$$= 14 \times 0.007854 = 0.1099 \text{ m}^3/\text{s}$$

Actual discharge,  $Q_{act} = A \times h / t = 1.767 \times 1.0 / 25 = 0.07068$

$$C_d = Q_{act} / Q_{th} = 0.07068 / 0.1099 = 0.643 \text{ (ans)}$$

Co-efficient of velocity,  $C_v = x / \sqrt{4 y H} = 4.3 / \sqrt{4 \times 0.5 \times 10}$

$$= 0.96 \text{ ans}$$

Co-efficient contraction  $C_c = C_d / C_v = 0.643 / 0.96 = 0.669 \text{ (ans)}$

## IMPORTANT QUESTIONS

### 1. Define orifice and notch.

- **Ans- A notch** is a device used for measuring the rate of flow of a liquid through a small channel or a tank.
- **A notch** is a device used for measuring the rate of flow of a liquid through a small channel or a tank.

### Long questions

1. Define orifice coefficients and establish the relation between them.
2. Derive an expression for discharge over rectangular orifice.
3. Derive an expression for discharge over triangular orifice.

P.K.MATH SIR

## CHAPTER-06

### FLOW THROUGH PIPE

#### 6.1 DEFINITION OF PIPE

Pipe is a closed conduit which is used to convey liquids and gases.

#### 6.2 LOSS OF ENERGY IN PIPES

When a fluid is flowing through a pipe, the fluid experiences some resistance due to which some of the energy of fluid is lost. This loss of energy is classified as:

**Major energy losses:** The viscosity causes loss of energy in the flows, which is known as frictional loss or major energy loss and it is calculated by the following formula;

(a) Darcy-weisbach formula

(b) Chezy's formula

**Minor energy losses:** The loss of energy due to change of velocity of the flowing fluid in magnitude or direction is called minor loss of energy. The minor loss of energy includes the following cases-

- a. Sudden expansion of pipe
- b. Sudden contraction of pipe
- c. Bending in pipe
- d. Pipe fittings

## 6.3 HEAD LOSS DUE TO FRICTION

(a) Darcy-Weisbach formula

The loss of head can be measured by the following equations

$$h_f = 4f L V^2 / (2gd)$$

Where  $h_f$  = Loss of head due to friction

$f$  = Co-efficient of friction which is a function of Reynolds number

$$f = 64/R_e \text{ (for } R_e < 2000 \text{) (laminar flow)}$$

$= 0.079/ R_e^{1/4}$  for  $R_e$  varying from 4000 to  $10^6$  (turbulent flow)

$L$  = Length of pipe

$V$  = mean velocity of flow

$D$  = Diameter of pipe

(b) Chezy's formula

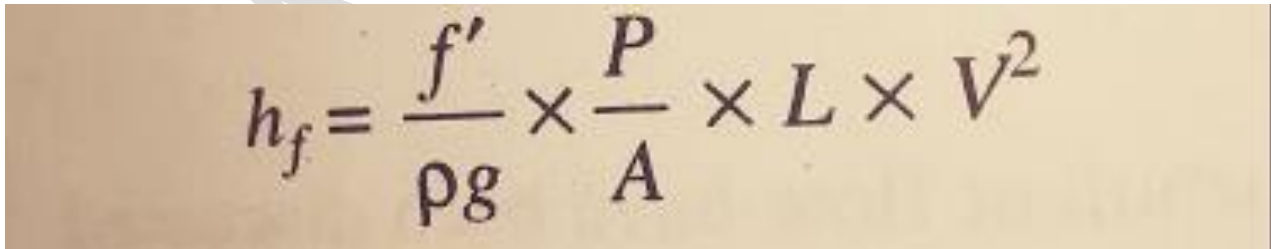
$$h_f = \frac{f'}{\rho g} \times \frac{P}{A} \times L \times V^2$$

Where,

$h_f$  = loss of head due to friction

$P$  = perimeter of pipe

$A$  = area of cross section of pipe

$L$  = length of pipe

$V$  = mean velocity of flow

Now the ratio of  $A/p = (\text{area of flow/wetted perimeter})$  is called hydraulic mean depth. It is denoted by  $m$ .

Hydraulic mean depth,  $m = A/P = d/4$

$$V = C\sqrt{mi}$$

### **6.4 problem**

**Find the head lost due to friction in a pipe of diameter 300mm and length 50m through which water is flowing at a velocity of 3m/s using (i) Darcy weisbach (ii) Chezy's Formula ( $c=60$ )**

(Take  $V=0.01$  stoke (for water))

#### **Solution:**

Given: Diameter of the pipe,  $d = 300\text{mm}$  (divide by '1000' to convert it from 'mm' to 'm')

Diameter  $d=0.3$  m

Length,  $L= 50\text{m}$

Velocity,  $v=3\text{m/s}$

Kinematic Viscosity,  $V=0.01\text{stoke}$

$$V=0.01\text{cm}^2/\text{s}$$

$$V=0.01 \times 10^{-4}\text{m}^2/\text{s}$$

By Darcy's Formula,

$$h_f=4f \times L \times v^2 \times d \times 2g$$

we know co-efficient of friction

$$f=0.079\text{Re}$$

$$\therefore \text{Re}=V \times dv = 3.0 \times 0.300 \times 0.01 \times 10^{-4}$$

$$Re=9 \times 10^5$$

$$\therefore f=0.079(9 \times 10^5)^{-1/4}$$

$$f=2.56 \times 10^{-3}$$

$$\text{or } f=0.00256$$

Therefore, Head lost,  $h_f=4 \times 0.00256 \times 50 \times 320.3 \times 2.0 \times 9.81$

$$h_f=782.87 \times 10^{-3}$$

$$h_f=0.7828 \text{ m}$$

Now by using Chezy's formula:-

$$V=c\sqrt{mi}$$

where,  $c=60$ ,  $m=d^4=0.304=0.075 \text{ m}$

$$3=60 \sqrt{0.075} \dots \dots \dots (i)$$

$$i=(360)^2 \times 10.075 \dots \dots \dots (ii)$$

By equating, we get

$$i=0.333$$

But,  $i=h_f/L$

$$\therefore 0.333=h_f/50$$

$$\therefore h_f=1.665 \text{ m}$$

### **6.5 HYDRAULIC GRADIENT LINE**

Hydraulic gradient line is basically defined as the line which will give the sum of pressure head and datum head or potential head of a fluid flowing through a pipe with respect to some reference line.

Hydraulic gradient line = Pressure head + Potential head or datum head

$$\text{H.G.L} = P/\rho g + Z$$

Where,

H.G.L = Hydraulic gradient line

$P/\rho g$  = Pressure head

$Z$  = Potential head or datum head

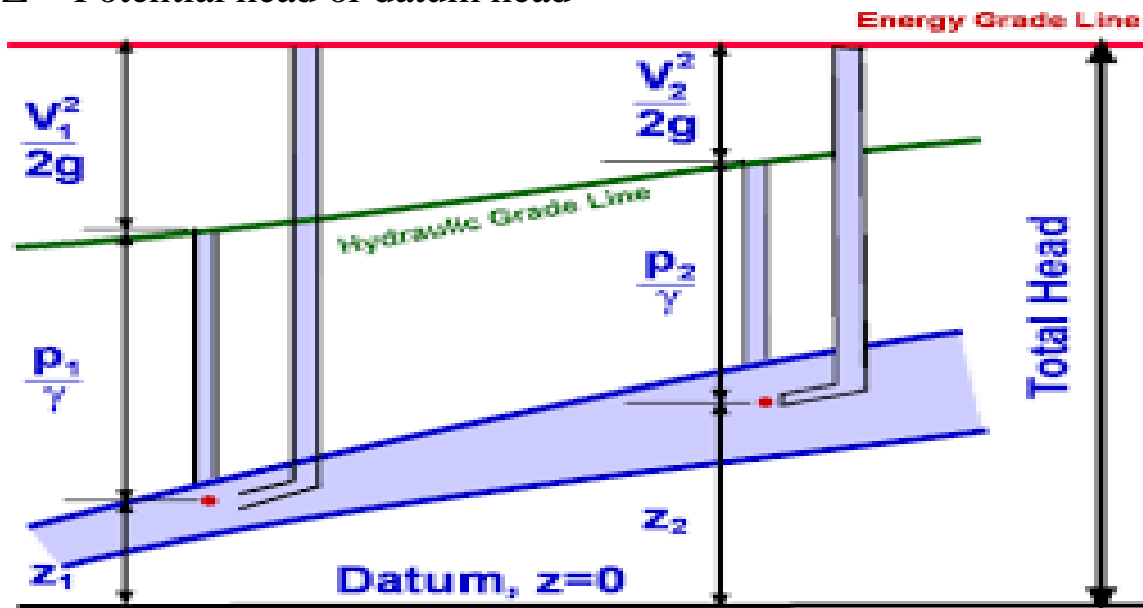

## **6.5 TOTAL ENERGY LINE**

Total energy line is basically defined as the line which will give the sum of pressure head, potential head and kinetic head of a fluid flowing through a pipe with respect to some reference line.

Total energy line = Pressure head + Potential head + Kinetic head

$$\text{H.G.L} = P/\rho g + Z + V^2/2g$$

Where,

T.E.L = Total energy line

$P/\rho g$  = Pressure head

$Z$  = Potential head or datum head

$V^2/2g$  = Kinetic head or velocity head

## Relation between hydraulic gradient line and total energy line

$$\text{H.G.L} = \text{E.G.L} - V^2/2g$$

### IMPORTANT QUESTIONS

#### SHORT QUESTIONS

##### **1. Define hydraulic gradient line.**

Ans-Hydraulic gradient line is basically defined as the line which will give the sum of pressure head and datum head or potential head of a fluid flowing through a pipe with respect to some reference line.

##### **2. Define pipe and hydraulic mean depth.**

Ans-

Pipe- it is a closed conduit which is used to carry fluid under pressure.

Hydraulic mean depth- it is defined as the area of flow section divided by the top water surface width.



## LONG QUESTIONS

1. Write down the expression of loss of energy due to friction according to Darcy's formula and Chezy's formula with proper notation.
2. Write in brief about Froude's law of fluid friction.
3. Find the head lost due to friction in a pipe of diameter 200mm and 300mm length through which water is flowing with a velocity of 5m/s using-
  - i. Darcy's formula
  - ii. Chezy's formula, take  $C = 50$  and  $f = 0.0079$

P.K.MATHS SIR

## CHAPTER – 07

### IMPACT OF JET

#### INTRODUCTION

The liquid comes out in the form of a jet from the outlet of the nozzle fitted in the outlet of the pipe through which the liquid is flowing under pressure. If some plate, which may be fixed or moving is placed in the path of the jet, a force is exerted by the jet on the plate. This force exerted by the jet on the plate is called impact of jet.

#### 7.1 IMPACT OF JET ON FIXED PLATE WHEN THE PLATE IS VERTICAL TO THE JET

Consider a jet of water coming out of the nozzle, strikes a flat vertical plate as shown in the Figure 1.

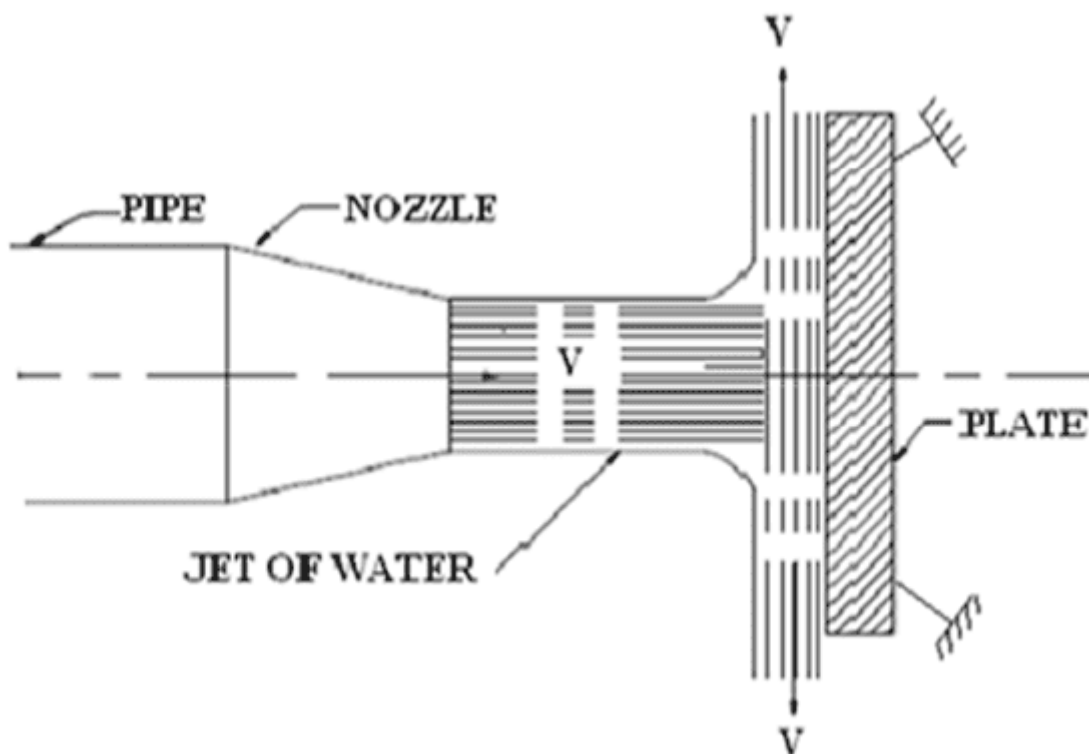

Figure 1

let,

$\rho$  = density of water

$a$  = area of jet =  $(\pi/4)d^2$

$v$  = absolute velocity of jet

The jet after striking the plate will move along the plate. But the plate is right angles to the jet. Hence the jet after striking will get deflected by  $90^\circ$ . Hence the component of the velocity of the jet, in the direction of the jet, after striking will be zero.

The force exerted by the jet on the plate in the direction of the jet.

$$= (\text{initial momentum} - \text{final momentum}) / \text{time}$$

$$= \text{mass} \times (\text{initial velocity} - \text{final velocity}) / \text{time}$$

$$= \text{mass} / \text{time} (\text{initial velocity} - \text{final velocity})$$

$$= \rho a v (v - 0)$$

$$= \rho a v^2$$

For deriving the above equation, we have taken initial velocity minus final velocity and not final velocity minus initial velocity. If the force exerted on the jet is to be calculated then final minus the initial velocity is taken. But if the force exerted by the jet on the plate is to be calculated, then initial velocity minus the final velocity is taken.

## 7.1 IMPACT OF JET ON MOVING PLATE WHEN THE PLATE IS VERTICAL TO THE JET

Consider, a jet of water strikes the flat moving plate moving with a uniform velocity away from the jet.

$v$  = Velocity of jet

$u$  = velocity of flat plate

Relative velocity of jet w.r.t plate =  $v - u$

Mass of water striking/ sec on the plate =  $\rho a (v - u)$

Force exerted by jet on the moving plate in the direction of jet

$F_x$  = Mass of water striking/ sec x [Initial velocity – Final velocity]

$$= \rho a (V - u) [(V - u) - 0]$$

$$= \rho a (V - u)^2$$

In this case, work is done by the jet on the plate as the plate is moving,

Work done by the jet on the flat moving plate

$$= \text{Force} \times \text{Distance in the direction of force} / \text{Time}$$

$$= F_x \times u = \rho a (V - u)^2 u$$

### Problem

Water is flowing through a pipe at the end of which a nozzle is fitted. The diameter of nozzle is 100 mm, and the head of water at the centre nozzle is 100 mm. find the force exerted by the jet of water on a fixed vertical plate. The coefficient of velocity is given as 0.95.

### solution

given data

diameter of nozzle,  $d = 100\text{mm} = 0.1\text{ m}$

head of water,  $H = 100\text{m}$

coefficient of velocity,  $C_v = 0.95$

area of the nozzle ,  $a = 0.007854\text{m}^2$

theoretical velocity of jet,

$$V_{th} = \sqrt{2gh} = \sqrt{2 \times 9.81 \times 100} = 44.294 \text{ m/s}$$

$C_v$  = actual velocity/ theoretical velocity

Actual velocity =  $C_v$  x theoretical velocity

$$= 0.95 \times 44.294 = 42.08 \text{ m/s}$$

$$F = \rho a v^2 = 1000 \times 0.007854 \times 42.08^2 = 13907.2 \text{ N} = 13.9 \text{ KN}$$

### 7.1 FORCE EXERTED BY A JET ON A STATIONARY INCLINED FLAT PLATE:

Let a jet of water, coming out from the nozzle; strike an inclined flat plate as shown in the figure.2.

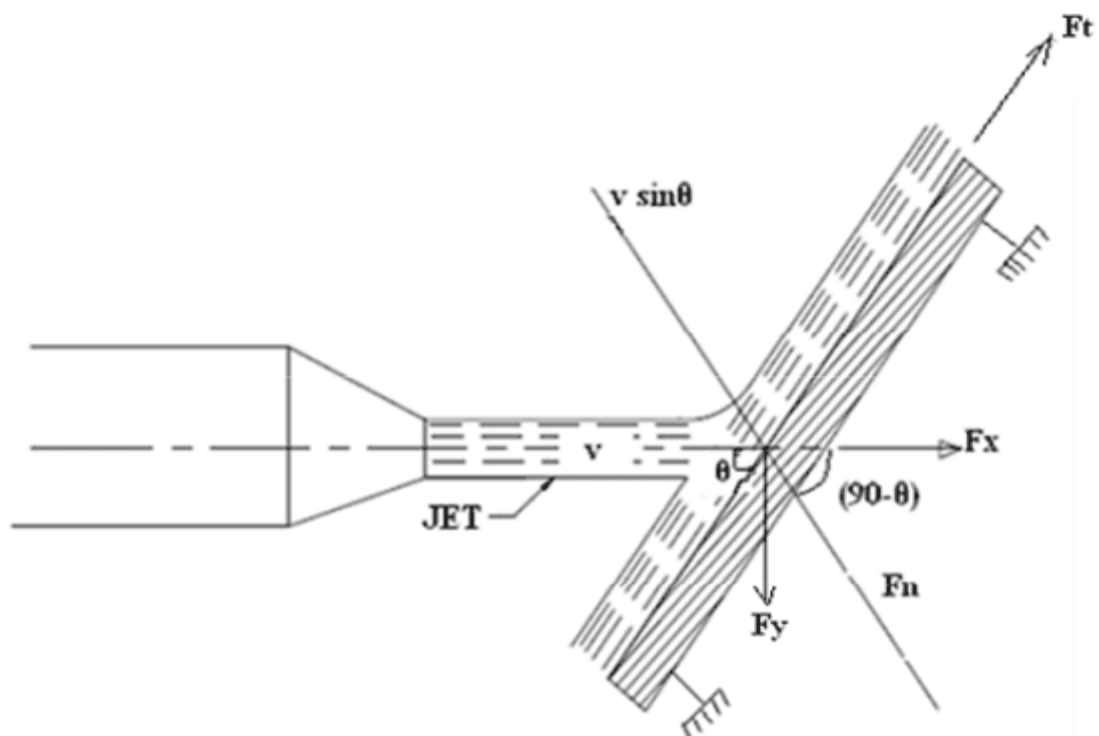

Figure.2.

Let

$$a = \text{area of jet} = (\pi/4)d^2$$

$v$  = velocity of the jet in the direction of  $X$   
 $\theta$  = Angle between the jet and the plate

then mass of water per second striking the plate =  $\rho av$

If the plate is assumed smooth and if it is assumed that there is no loss of energy due to the impact of the jet, then the jet will move over the plate after striking with a velocity equal to initial velocity i.e., with a velocity  $V$ .

Let find the force exerted by the jet on the plate In the direction normal to the plate. Let this force is represented by  $F_n$

then,  $F_n$  = Mass of the jet striking per second  $\times$  [initial velocity of the jet before striking in the direction of  $n$  - final velocity of the jet after striking in the direction of  $n$ ]

$$F_n = \rho av [ v \sin\theta - 0 ] = \rho av^2 \sin\theta$$

If the force can be resolved into two components, one in the direction of the jet and the other perpendicular to the direction of the flow. Then we have,

$$F_x = \rho av^2 \sin\theta$$

(along the direction of the flow) and

$$F_y = \rho av^2 \sin\theta \cos\theta$$

(perpendicular to flow)

### **7.1 FORCE EXERTED BY A JET ON A MOVING INCLINED FLAT PLATE:**

Consider, a jet of water strikes the flat moving plate moving with a uniform velocity away from the jet.

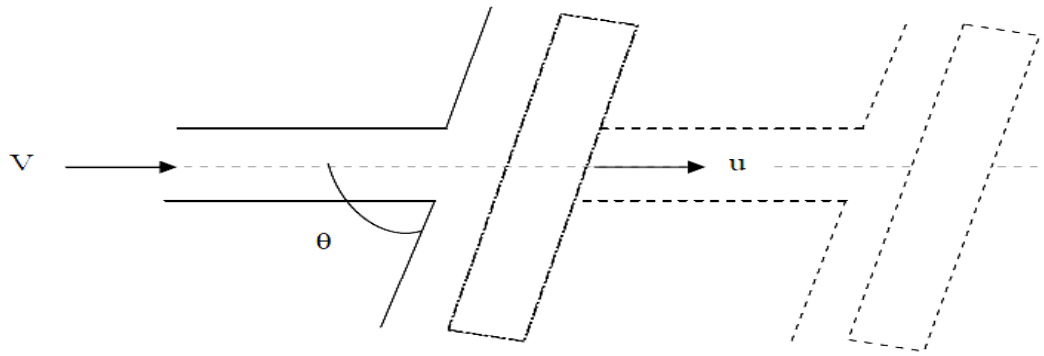

$v$  = Velocity of jet

$u$  = velocity of flat plate

Relative velocity of jet w.r.t plate =  $v - u$

If the plate is smooth, it is assumed that the loss of energy due to impact of jet is zero, then the jet of water leaves the inclined plate with a velocity  $(V - u)$ .

Force exerted by jet on the inclined plate in the direction normal to the jet

$F_n$  = Mass of water striking/ sec x [Initial velocity – Final velocity]

$$= \rho a(V - u) [(V - u) \sin\theta - 0]$$

$$= \rho a(V - u)^2 \sin\theta$$

This normal force can be resolved into two components one in the direction of jet and other perpendicular to the direction of jet

Component of  $F_n$  in the direction of jet.

$$F_x = \rho a(V - u)^2 \sin^2\theta$$

Component of  $F_n$  in the direction perpendicular to the direction of jet

$$F_y = \rho a(V - u)^2 \sin \theta \cos \theta$$

Work done by the jet on the flat moving plate

$$\begin{aligned} &= \text{Force} \times \text{Distance in the direction of force} / \text{Time} \\ &= \rho a(V - u)^2 \sin^2 \theta \times u \end{aligned}$$

## **7.2 FORCE EXERTED BY THE JET OF WATER ON SERIES OF VANES**

Let,

$v$  = Velocity of jet

$a$  = area of x-section of jet.

$u$  = velocity of vane

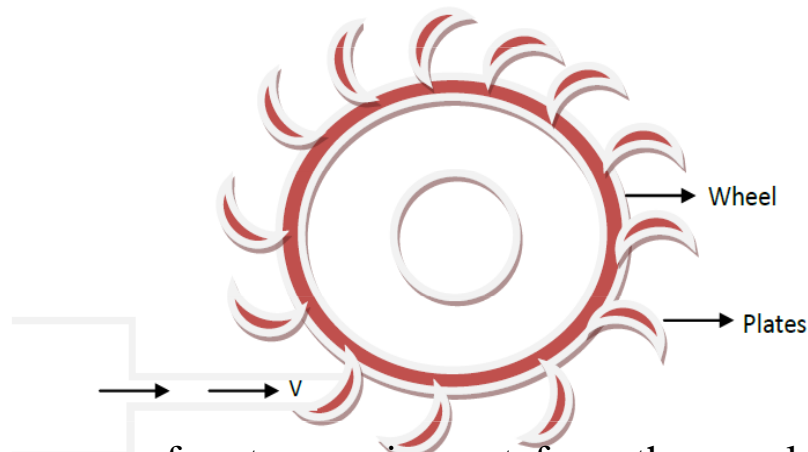

In this, mass of water coming out from the nozzle is always in constant with plate. When all plates are considered.

Mass of water striking/s w.r.t plate =  $\rho av$

Jet strikes the plate with a velocity =  $V - u$

f



Force exerted by the jet on the plate in the direction of motion of plate = Mass/sec x (Initial velocity – Final velocity)

Work done by the jet on the series of blade per second = force x dist. Per second in the direction of force

$$= F_x \times u = \rho a V (V - u) \times u$$

Kinetic energy of jet per second =  $\frac{1}{2} m V^2$

$$= \frac{1}{2} \rho a V \times V^2 = \frac{1}{2} \rho a V^3$$

Efficiency,  $\eta = \frac{\text{Work done by jet/s}}{\text{K.E by jet/s}}$

$$= \frac{\rho a V (V - u) \times u}{\frac{1}{2} (\rho a V) V^2}$$

$$\eta = \frac{2 u (V - u)}{V^2}$$

Condition for maximum efficiency,  $\frac{d\eta}{du} = 0$

$$= \frac{d}{du} \left[ \frac{2 u (V - u)}{V^2} \right] = 0$$

$$= \frac{d}{du} \left[ \frac{2 u V - 2 u^2}{V^2} \right] = 0$$

$$= \left[ \frac{2 V - 4u}{V^2} \right] = 0$$

''

$$u = \frac{v}{2}$$

Put the values of u in

$$\eta = \frac{2u(V-u)}{V^2}$$

### 7.3 IMPACT OF JET ON MOVING CURVED VANES

Consider a jet of water entering and leaving a moving curved vane as shown in fig.4

$$\eta_{max} = \frac{2 \frac{V}{2} (V - \frac{V}{2})}{V^2}$$

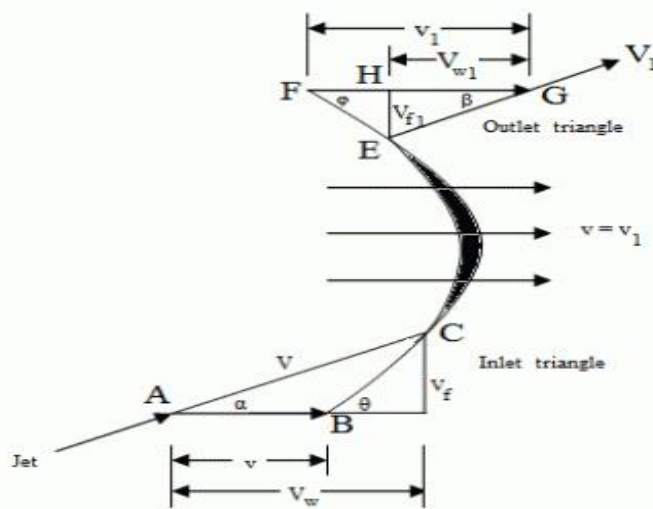

Fig-4 : Jet impinging on a moving curved vane

- $V$  = Velocity of the jet (AC), while entering the vane,
- $V_1$  = Velocity of the jet (EG), while leaving the vane,
- $U_1, U_2$  = Velocity of the vane (AB, FG)
- $\alpha$  = Angle with the direction of motion of the vane, at which the jet enters the vane,
- $\beta$  = Angle with the direction of motion of the vane, at which the jet leaves the vane,
- $V_r$  = Relative velocity of the jet and the vane (BC) at entrance (it is the vertical difference between  $V$  and  $U_1$ )

- $V_{r1}$  = Relative velocity of the jet and the vane (EF) at exit (it is the vertical difference between  $V_1$  and  $U_1$ )
- $\Theta$  = Angle, which  $V_r$  makes with the direction of motion of the vane at inlet (known as vane angle at inlet),
- $\beta$  = Angle, which  $V_{r1}$  makes with the direction of motion of the vane at outlet (known as vane angle at outlet)
- $V_w$  = Horizontal component of  $V$  (AD, equal to). It is a component parallel to the direction of motion of the vane (known as velocity of whirl at inlet),
- $V_{w1}$  = Horizontal component of  $V_1$  (HG, equal to). It is a component parallel to the direction of motion of the vane (known as velocity of whirl at outlet),
- $V_f$  = Vertical component of  $V$  (DC, equal to). It is a component at right angles to the direction of motion of the vane (known as velocity of flow at inlet),
- $V_{f1}$  = Vertical component of  $V_1$  (EH, equal to). It is a component at right angles to the direction of motion of the vane (known as velocity of flow at outlet),
- $a$  = Cross sectional area of the jet. As the jet of water enters and leaves the vanes tangentially, therefore shape of the vanes will be such that  $V_r$  and  $V_{r1}$  will be a long with tangents to the vanes at inlet and outlet.

The relations between the inlet and outlet triangles (until and unless given) are: (i)  $V=V_1$ , and (ii)  $V_r=V_{r1}$  we know that the force of jet, in the direction of motion of the vane,

$F_x$  = mass of water striking per second  $\times$  change in whirl velocity

$$= \rho a (V-u) \times [ (V-u) - (-(V-u) \cos \theta) ]$$

$$= \rho a (V-u) \times [ (V-u) + (V-u) \cos \theta ]$$

$$= \rho a (V-u)^2 \times [1 + \cos \theta]$$

Work done by the jet in the direction of jet=

=  $F_x$  x distance travelled per second in the direction of x

$$= \rho a (V-u)^2 \times [1+ \cos \theta] \times U$$

$$= \rho a (V-u)^2 \times U \times [1+ \cos \theta]$$

### PROBLEM

A jet of water of diameter 7.5 m strikes a curved plate at its centre with a velocity of 20 m/s. the curved plate is moving with a velocity of 8 m/s in the direction of the jet. The jet is deflected through an angle of  $165^\circ$ . Assuming the plate smooth find:

- (1) Force through on the plate in the direction of jet,
- (2) Power of the jet, and
- (3) Efficiency of the jet

### solution

Given data

Diameter of the jet,  $d = 7.5 \text{ cm} = 0.075 \text{ m}$

Area,  $a = A = \pi r^2 = 0.004417 \text{ m}^2$

Velocity of jet,  $v = 20 \text{ m/s}$

Velocity of plate,  $u = 8 \text{ m/s}$

Angle of deflection of the jet,  $= 165^\circ$

Angle made by the relative velocity at the outlet of the plate,  $\theta = 15^\circ$

- 1) Force exerted by the jet on the plate in the direction of jet,

$$F_x = \rho a (V-u)^2 \times [1+ \cos \theta]$$

$$= 1000 \times 0.004417 \times (20-8)^2 [1+ \cos 15]$$

$$= 1250.38 \text{ N (ans)}$$

Work done by the jet in the direction of jet=  $F_x \times u$

$$= 1250.38 \times 8 = 10003.38 \text{ N m/s}$$

Power of the jet =  $10003.38/1000 = 10 \text{ kw (ans)}$

Efficiency of the jet = output/input

= work done by the jet per second/ kinetic energy of jet per second

= 56.4% (ans)

Velocity triangles, work done and efficiency of moving curved plate

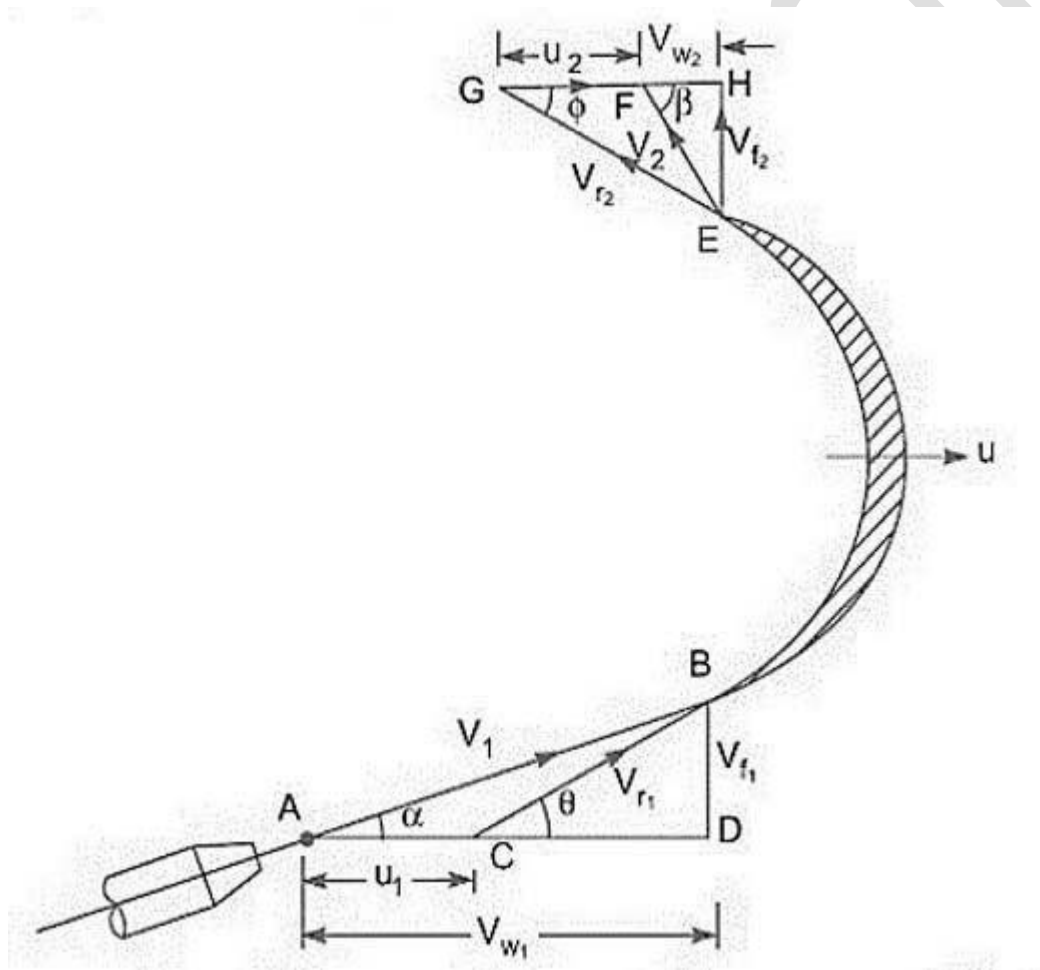

$V_1$  = Velocity of the jet at inlet

$u_1$  = velocity of the vane at inlet

$V_{r1}$  = relative velocity of the jet and plate at inlet

$\alpha$  = angle between the direction of the jet and direction of motion of the plate (Guide blade angle)  $\Theta$  = angle made by the relative velocity with direction of motion at the inlet (Vane angle at inlet)  $V_{w1}$  = velocity of whirl at inlet (component of  $V_1$  in the direction of motion)

$V_{f1}$  = velocity of flow at inlet (component of  $V_1$  in the direction perpendicular of motion)

Similarly,  $V_2$  = Velocity of the jet at outlet

$u_2$  = velocity of the vane at outlet

$V_{r2}$  = relative velocity of the jet and plate at outlet

$\beta$  = angle between the direction of the jet and direction of motion of the plate (Guide blade angle)  $\Phi$  = angle made by the relative velocity with direction of motion at the outlet (Vane angle at outlet)  $V_{w2}$  = velocity of whirl at outlet (component of  $V_2$  in the direction of motion)

$V_{f2}$  = velocity of flow at outlet (component of  $V_2$  in the direction perpendicular of motion)

Inlet velocity Triangle:  $AC = V_1$ ,

$AB = u_1$ ,  $BC = V_{r1}$ ,  $AD = V_{w1}$ ,  $BD = V_{f1}$

Outlet velocity triangle:  $GF = V_2$ ,  $EF = u_2$ ,  $EG = V_{r2}$ ,  $FH = V_{w2}$ ,  $GH = V_{f2}$

As water glides smoothly, therefore neglecting friction between vane and water  $V_{r1} = V_{r2}$  Also tip velocity at inlet and outlet are same.

$$u_1 = u_2$$

Force exerted by the jet in the direction of motion = mass of water striking per sec  $\times$  (initial velocity with which jet strikes the water in the dir. Of jet – final velocity in Direction of jet)

$$F = \rho a V_{r1} [ (V_{w1} - u_1) - (-u_2 + V_{w2}) ]$$

$$= \rho a V r_1 [ (V w_1 - u_1 + u_2 + V w_2)]$$

$$F = \rho a V r_1 [ V w_1 + V w_2]$$

If  $\beta = 90^\circ$ , then  $V w_2 = 0$  .....

$$F = \rho a V r_1 [ V w_2]$$

If  $\beta > 90^\circ$  then  $V w_2 =$  .....

$$F = \rho a V r_1 [ V w_1 - V w_2]$$

In general,

$$F = \rho a V r_1 [ V w_1 \pm V w_2]$$

Work Done: Work done per sec by the jet = Force X Distance per sec

$$W.D. = F \times \text{distance time} = F = \rho a V r_1 [ V w_1 \pm V w_2] \times u$$

**Work Done:**

Work done per sec per unit weight of striking per sec = Force X Distance per sec / weight of water striking per sec

$$= 1/g [ [ V w_1 \pm V w_2 ] \times u \text{ Nm/N}$$

Efficiency: It is a ratio of work done per sec to initial K.E. of Work done per sec per unit weight of striking per sec of jet

$$= \rho a V r_1 [ V w_1 \pm V w_2 ] \times u / (1/2 \rho a V_1 \times V_1^2)$$

### IMPORTANT QUESTIONS

#### Short question

##### 1. What do you mean by impact of jet?

Ans -The liquid comes out in the form of a jet from the outlet of the nozzle fitted in the outlet of the pipe through which the liquid is flowing under pressure. if some plate, which may be fixed or moving is placed in the path of the jet, a force is exerted by the jet on the plate. This force exerted by the jet on the plate is called impact of jet.

### Long questions

1. Derive an expression of force exerted by a jet on stationary curved plate? 2018(s)

2. A jet of water of diameter 7.5cm strikes a velocity of 20m/s. The curved plate is moving with a velocity of 8m/s in the direction of jet. The jet is deflected through an angle of  $165^\circ$ . Assuming the plate is smooth and find-

(i) force exerted on plate in the direction of jet.

(ii) power of jet

(iii) efficiency of jet 2018(s)

3. Water is flowing through a pipe at the end of which a nozzle is fitted. The diameter of nozzle is 120mm and head of water at the centre of nozzle is 90m. Find the force exerted by the jet of water on a fixed vertical plate. Take a coefficient of velocity is given as 0.95? 2019(s)